

CI/SfB 1976
811 Hi (H122) (J3)

1988

Cyclone-resistant houses for developing countries



bre BUILDING
RESEARCH
ESTABLISHMENT
Department of the Environment

£8.00 net

Cyclone-resistant houses for developing countries

Alan Mayo

Building Research Station

**Building Research Establishment
Overseas Division
Garston, Watford
WD2 7JR**

Technical enquiries should be addressed to:

Head, Overseas Division
Building Research Establishment
Garston, Watford WD2 7JR

Price lists for all available
BRE publications can be
obtained from:
Publications Sales
Building Research Establishment
Garston, Watford, WD2 7JR
Tel: Garston (0923) 664444

BR 131
ISBN 0 85125 292 3

© Crown copyright 1988
First published 1988

Limited extracts from the text may be reproduced
provided the source is acknowledged. For more extensive
reproduction, please write to the Head, Overseas Division,
Building Research Establishment.

FOREWORD

Each year in several areas of the world windstorms cause loss of life and a great deal of damage, especially to low-cost and self-built houses. There is a particular need to help people in developing countries by providing technical advice on simple and reliable methods of improving the resistance of low-cost houses to such windstorms.

This publication is a review of the work carried out overseas by the Building Research Establishment on the effects of wind on buildings. It draws together the results of studies made in various developing countries to provide information which is applicable throughout the world.

It describes the characteristics of windstorms and their effects on buildings and sets out general principles for the location and structural design of low-cost houses. Specific construction details are included which emphasise the importance of strong connections between components to maintain structural integrity during windstorms.

I am sure that this review, which is published with the support of the Overseas Development Administration, will be of benefit to the designers, builders and inhabitants of houses in those developing countries which experience strong winds.

Dr R F Stevens, former Head of Overseas Division
Building Research Establishment

CONTENTS

| | Page |
|--|------|
| INTRODUCTION | 1 |
| WIND FORCES ON A BUILDING | 5 |
| BRE EXPERIENCE IN DEVELOPING COUNTRIES | 7 |
| Mauritius | 7 |
| Philippines | 8 |
| Hong Kong | 8 |
| Sri Lanka | 8 |
| Caribbean | 8 |
| South Pacific | 11 |
| DESIGN CONSIDERATIONS | 16 |
| Location | 16 |
| Shape | 18 |
| Openings | 19 |
| CONSTRUCTION DETAILS | 20 |
| Foundations | 20 |
| Floor | 23 |
| Walls | 24 |
| Roof | 28 |
| MAINTENANCE FOR OCCUPIERS | 32 |
| FURTHER ASSISTANCE | 32 |
| REFERENCES | 33 |

ACKNOWLEDGEMENTS

This report has been written with grateful acknowledgement of the extensive work in this field by my predecessor Dr K J Eaton and other colleagues.

It is published as part of a research project undertaken by BRE and funded by the Overseas Development Administration, London.

INTRODUCTION

All buildings, including low-cost housing, should be constructed so that they can safely resist the strongest winds likely to be encountered. In tropical regions, these conditions arise during windstorms called cyclones, hurricanes or typhoons, depending on the area of the world in which the storm occurs. Whichever term is used, the characteristics are the same — a rapidly revolving wind system with a mean wind speed of 33 m/sec or more, which may cover an area more than 800 km across. At the centre or 'eye' of such a wind system, the atmospheric pressure is very low, creating relatively calm conditions. Typically, the eye of a cyclone may be 40 km across.

Cyclones originate over tropical oceans and seas when air is still and the water warm. These conditions can exist for lengthy periods during late summer in six main areas of the world¹ (Figure 1). Many cyclones dissipate at sea but those which come ashore can cause serious damage to buildings (Figure 2) resulting in many people being made homeless as well as causing injury and loss of life.

Serious damage occurs to some buildings owing to the failure of one or more of the main structural elements, but more frequently damage arises because of a lack of adequate fixings between the structural elements and between the buildings and its foundations. From a knowledge of wind speed, the shape and location of the building and the strength of the materials from which it is constructed, detailed calculations may be made to ensure that the building will safely resist the forces exerted on it during a cyclone²⁻⁵. However, by careful attention to a relatively small number of points, satisfactory low-cost housing may be constructed or strengthened using a variety of standard fixing details and components without the need for complex engineering calculations.

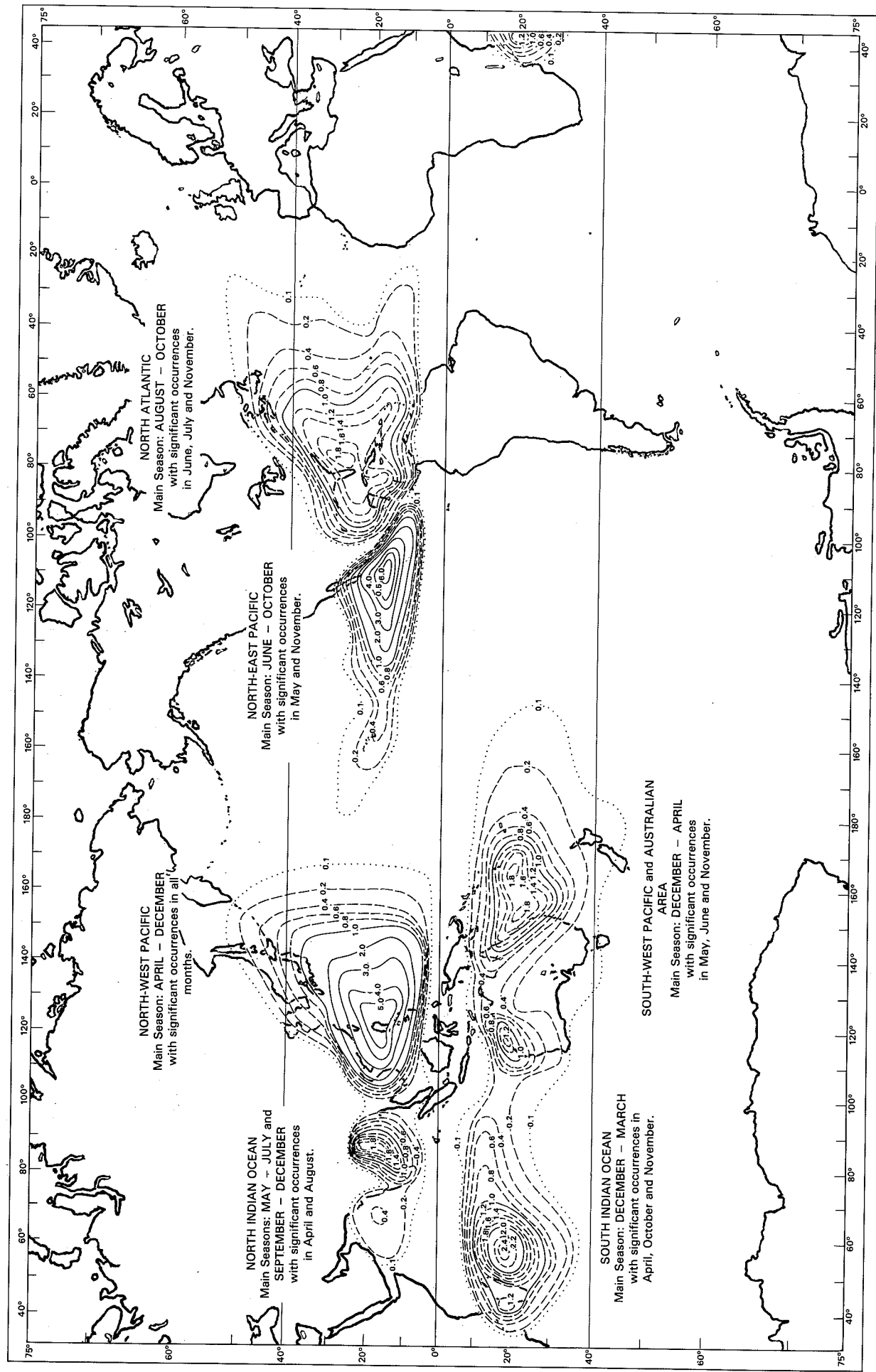

Figure 1 Areas of tropical cyclones showing the average number of occurrences per five-degree square per year

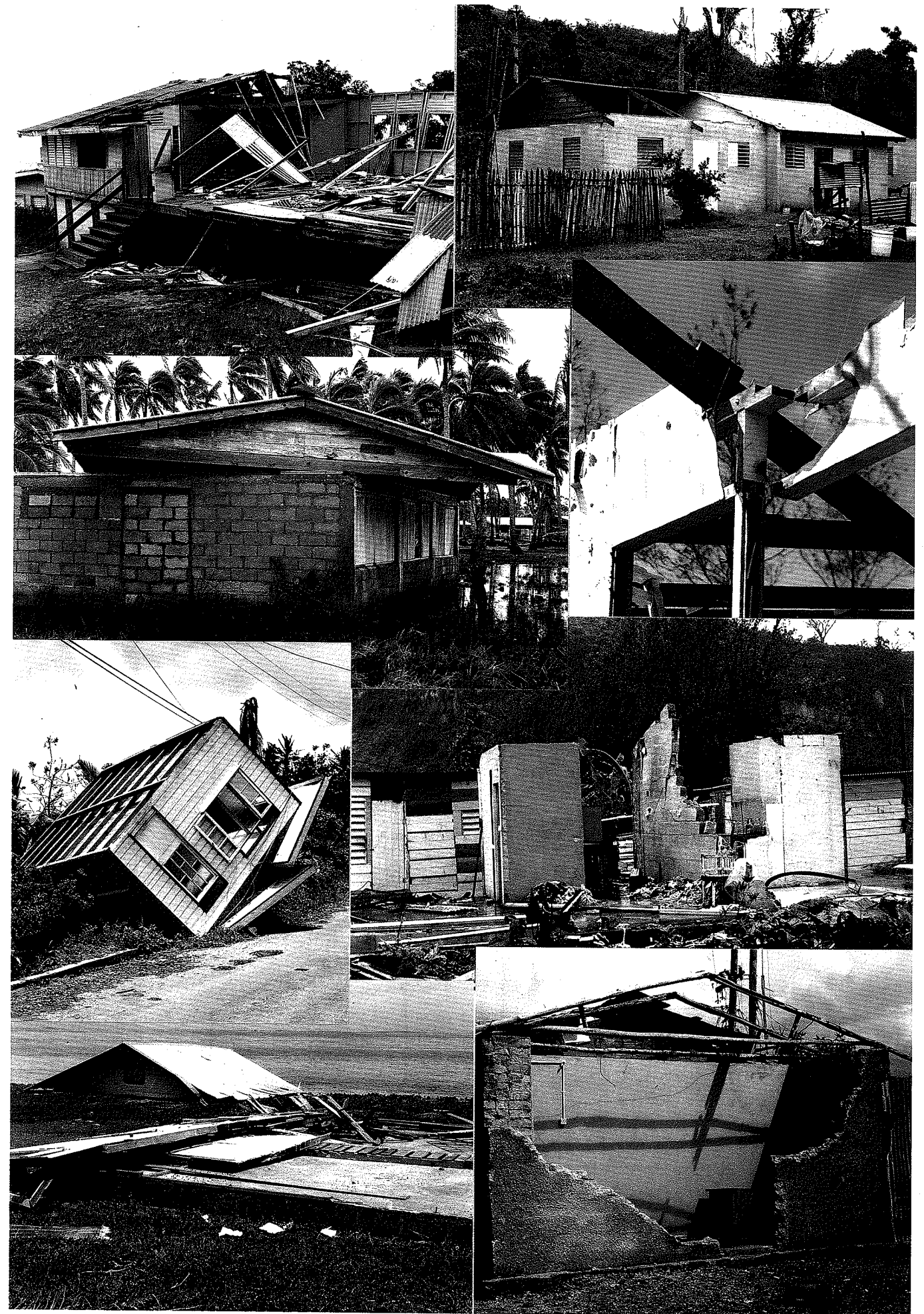
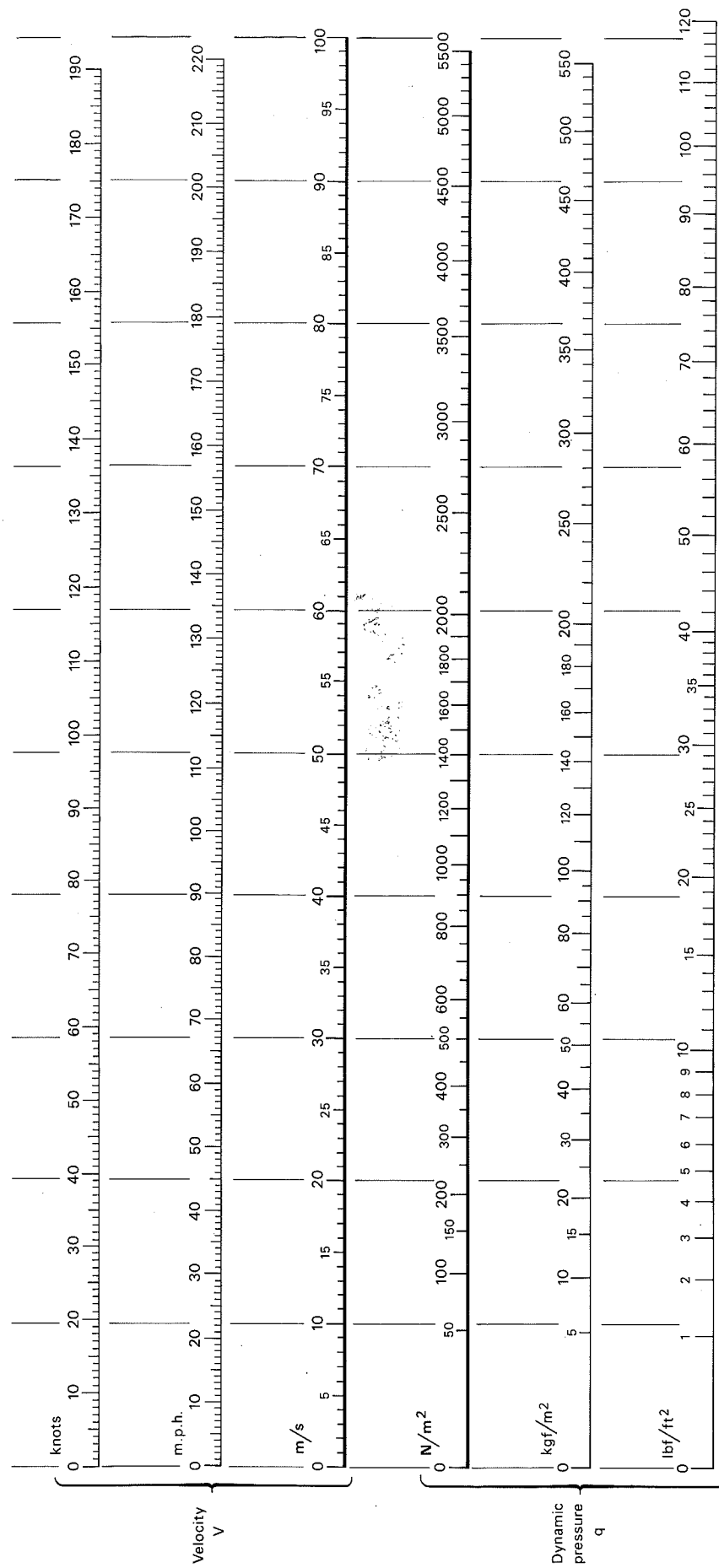

Figure 2 Examples of damage to buildings by cyclones

Table 1 Conversion chart for wind speed and dynamic pressure



1 m/s = 1.95 knots = 2.24 mph
 1 kgf = 9.81 Newtons (N) = 2.21 lbf

WIND FORCES ON A BUILDING

The forces exerted on the various elements of a building during a cyclone act in different directions relative to the wind direction and are proportional to the square of the wind speed, eg if the wind speed increases from 35 m/sec to 70 m/sec, the wind forces increase by four times (Table 1). From a statistical analysis of measurements of wind speeds over a number of years throughout the world, the UK Meteorological Office has derived values for the maximum gust speed likely to be experienced once in a period of 50 years. Table 2 lists the once-in-50-years gust speeds for those countries which experience cyclones. For the larger countries, a range of speeds is given which reflects the significant variations which exist within each country.

Table 2 Once-in-50-years design gust speeds for various countries which experience cyclones

| | metres per sec (m/s)* |
|---------------------------|-----------------------|
| NORTH INDIAN OCEAN | |
| India | 34 - 61 |
| Sri Lanka | 36 |
| SOUTH INDIAN OCEAN | |
| Mauritius | 68 |
| Mozambique | 31 - 38 |
| Reunion | 57 |
| Rodriguez | 90 |
| NORTH-WEST PACIFIC | |
| Hong Kong | 71 |
| Japan | 27 - 68 |
| Macau | 56 |
| Malaysia | 25 - 35 |
| Philippines | 20 - 69 |
| South Korea | 30 - 55 |
| Taiwan | 79 |
| SOUTH-WEST PACIFIC | |
| New Caledonia | 35 - 54 |
| Pacific (East) Islands | 27 - 52 |
| Samoa | 39 |
| NORTH ATLANTIC | |
| Antigua | 53 |
| Barbados | 53 |
| Bermuda | 60 |
| Grenada | 45 |
| Jamaica | 53 |
| Martinique | 44 |
| Mexico | 27 - 60 |
| Puerto Rico | 49 |
| St Barthélemy | 53 |
| Trinidad and Tobago | 42 |
| Venezuela | 29 - 42 |

*1m/s = 1.95 knots = 2.24 mph

Topography is an important factor influencing wind speeds, particularly near the tops of hills and along the bottoms of open-ended valleys where increases in wind speed of between 10 and 20% are common (Figure 3).

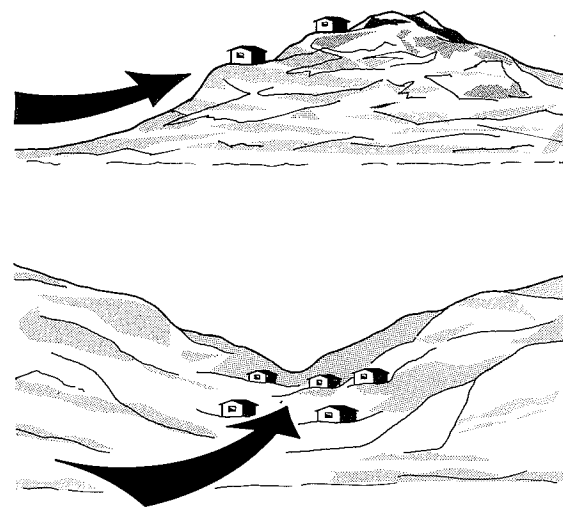

Figure 3 Hills and open-ended valleys increase wind speeds

Similarly, long stretches of open ground such as coastal plains provide little protection from cyclones sweeping inland from the sea.

The forces exerted by the wind on the walls and roof of a building are governed not only by the wind speed, but also by the shape of the building and the direction of the wind relative to the building (Figure 4).

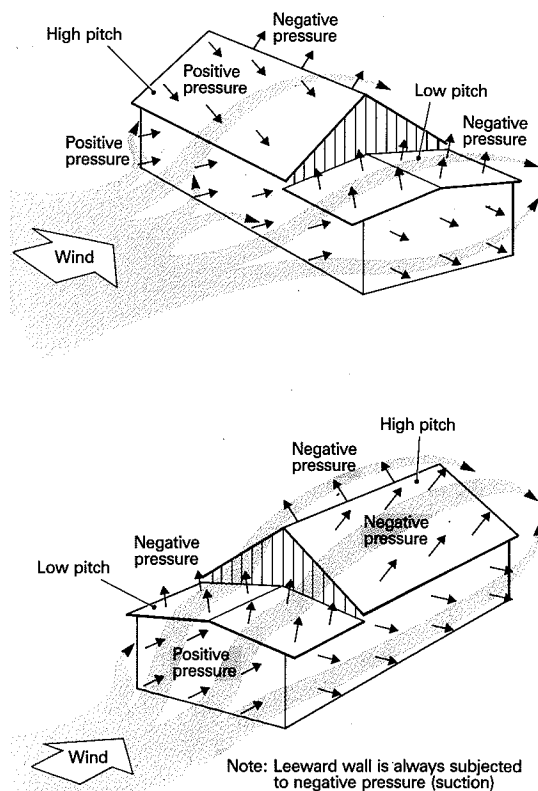

Figure 4 Wind forces on walls and roofs of buildings are affected by direction of wind and shape of buildings

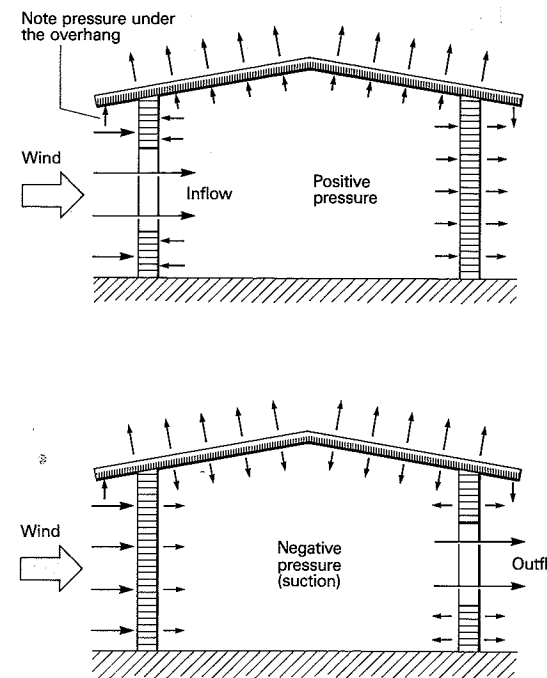

Figure 5 The effect of openings in windward and leeward faces

The total wind force on a wall or roof depends on the difference between the pressures on the inner and outer faces of the wall or roof. Open doors, windows and ventilators on the windward side of a building cause the air pressure to increase inside the building. This has the effect of increasing the total force on those elements of the building which experience external negative pressures, and reducing the total force on those elements subjected to external positive pressures (Figure 5).

Conversely, openings in walls in the lee or parallel to the wind direction cause a reduction in air pressure inside the building. This increases the total force on the windward wall and counteracts the external negative pressures on the remaining walls and the roof.

Local increases in the forces due to wind occur where the air flow over a building changes direction abruptly — at corners, roof edges and the ridge. Similarly, large roof overhangs at the eaves give rise to localised increases in wind forces.

BRE EXPERIENCE IN DEVELOPING COUNTRIES

Over the past 30 years, BRE staff have been engaged in assessing the effects of wind on buildings. This work has included studies of the effects of tropical windstorms throughout the world and many countries have benefited directly from the research expertise and technical advice made available as a result of these studies^{6,7}.

MAURITIUS. Following cyclones 'Alix' and 'Carol' which struck the island in 1960 causing severe and extensive damage to buildings, an investigation was undertaken by BRE. The distribution of wind forces on buildings and the resulting damage patterns were related to ground topography, roof pitch, building shape and architectural features. This field experience confirmed the validity of much of the previous experimental work undertaken with models. Suction forces were recognised as a major cause of damage and roof anchorage was shown to be the most critical factor requiring attention in efforts to reduce damage caused by wind. The beneficial effects of ridge ventilators were also noted. These lower the internal pressure within a building, thereby reducing the total force on those areas of roofs and walls subject to external suction forces.

PHILIPPINES. As part of a research project initiated by the US National Bureau of Standards involving the Philippines, Jamaica and Bangladesh, collaborative work by BRE helped to establish a methodology for the estimation of maximum wind speeds and the development of wind tunnel modelling techniques. Also, data were collected for analysis leading to the derivation of basic wind speeds and appropriate pressure coefficients which assisted with the development of construction details able to withstand high wind forces. Workshop presentations were held to disseminate the information gained from this work and the US National Bureau of Standards published a five-volume report⁸ on building in areas subject to severe wind conditions.

HONG KONG. Much useful information was obtained on the effects of wind on high-rise buildings as a result of co-operation between BRE and the University of Hong Kong. Over a period of seven years, data were collected on maximum wind speed gusts and the associated wind pressures on a ten-storey experimental building⁹ which was a half-scale replica of Royex House in London. Both buildings were fully instrumented with anemometers and pressure transducers and useful comparisons were made between the two sets of data obtained. After analysis, this data provided a valuable input to both the UK and Hong Kong wind-loading codes.

SRI LANKA. Following an aid project by the Australian Government, a wind-loading design manual was published¹⁰ and housing designed and constructed in accordance with it was assessed by BRE. This showed that the design manual was readily understood and applied by local technical staff, and it was clear that the standard of control and workmanship was good.

CARIBBEAN. A major project on cyclone-resistant housing has been undertaken by BRE on the island of St Vincent, and much of the information obtained and advice given is applicable to islands throughout the Caribbean^{11,12}. Following an appraisal of local information on wind speeds, basic design parameters were established and used to design three low-cost house types.

House 1 (Figure 6) is 7.3 m × 6.1 m in plan with a solid concrete floor. The hardwood columns, beams, rafters and purlins are interconnected with rigid brackets and the roof clad with 'Onduline', a corrugated bitumen-fibre sheeting.

House 2 (Figure 7) is 6.1 m × 3.0 m in plan with a hardwood substructure and floor. Again, the hardwood columns, beams, rafters and purlins are all inter-connected with rigid brackets and the roof clad with 'Onduline' sheeting.

House 3 (Figure 8) is 7.3 m × 6.1 m in plan with a solid concrete floor. It has reinforced hollow-concrete block columns with a hardwood ring-beam, trusses and purlins, all rigidly interconnected and supporting 'Onduline' roof sheeting.

Trial houses of each type were constructed during the first half of 1979 when the estimated costs of materials and labour were £750, £500 and £750 respectively. The designs and methods of construction permit a variety of materials to be used to infill the walls depending on what is most readily available. The floors may be of solid or hollow construction to suit the prevailing site conditions. Internal partitions may be erected to suit individual needs and, should it become necessary, each house may be readily extended. The robustness of these designs was proved within 12 months of erection of the trial houses, when hurricane 'Allan' passed close to St Vincent. Maximum wind speeds on the island were stated to be between 32 and 36 m/s and although many local squatter homes were severely damaged and some totally destroyed, all the trial houses performed well, remaining intact and undamaged.

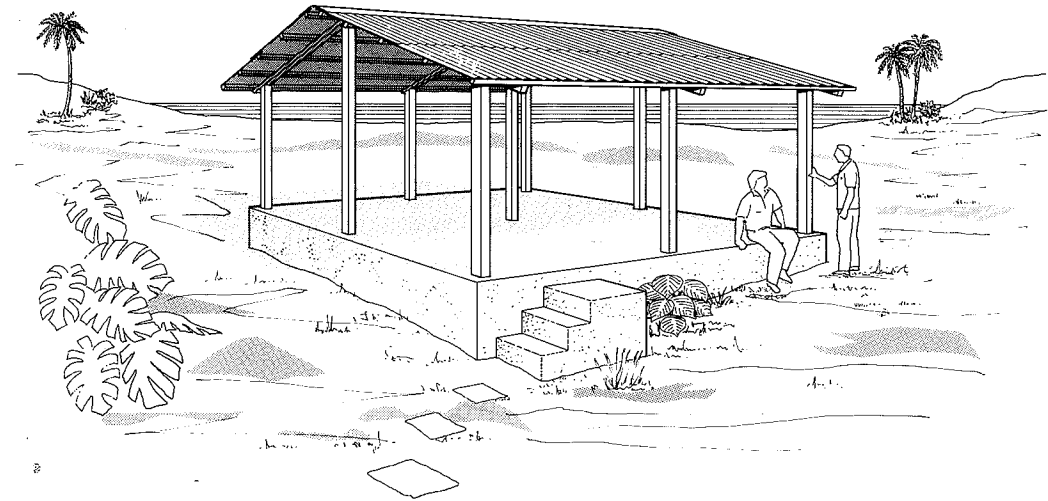

Figure 6 Building Research Establishment/Housing & Land Development Corporation St Vincent low-income house (type 1) — 45 square metres

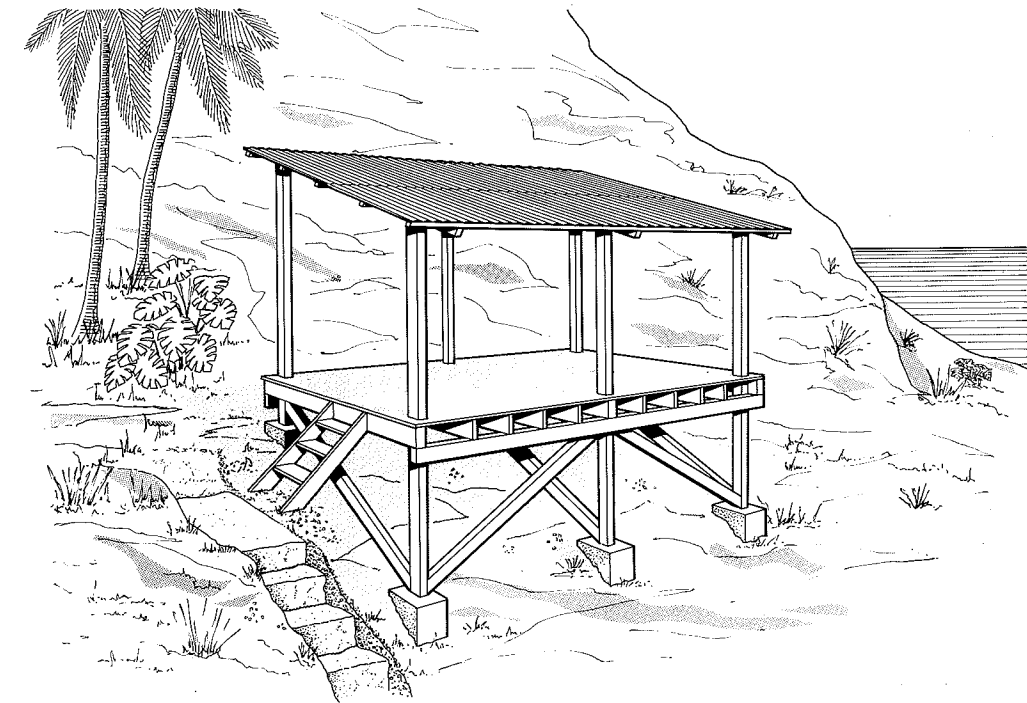

Figure 7 BRE-HLDC St Vincent low-income house (type 2) — 19 square metres

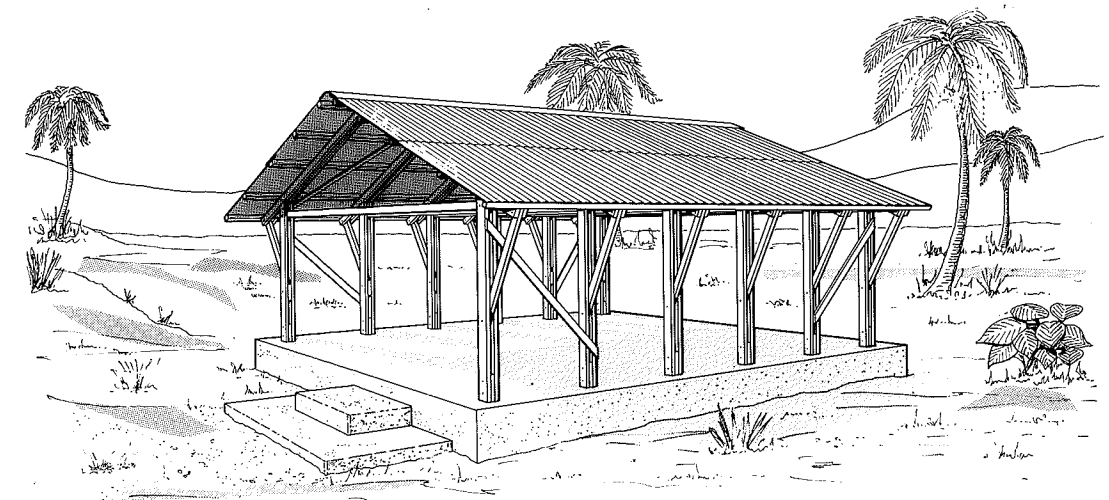

Figure 8 BRE-HLDC St Vincent low-income house/community building — 51 square metres

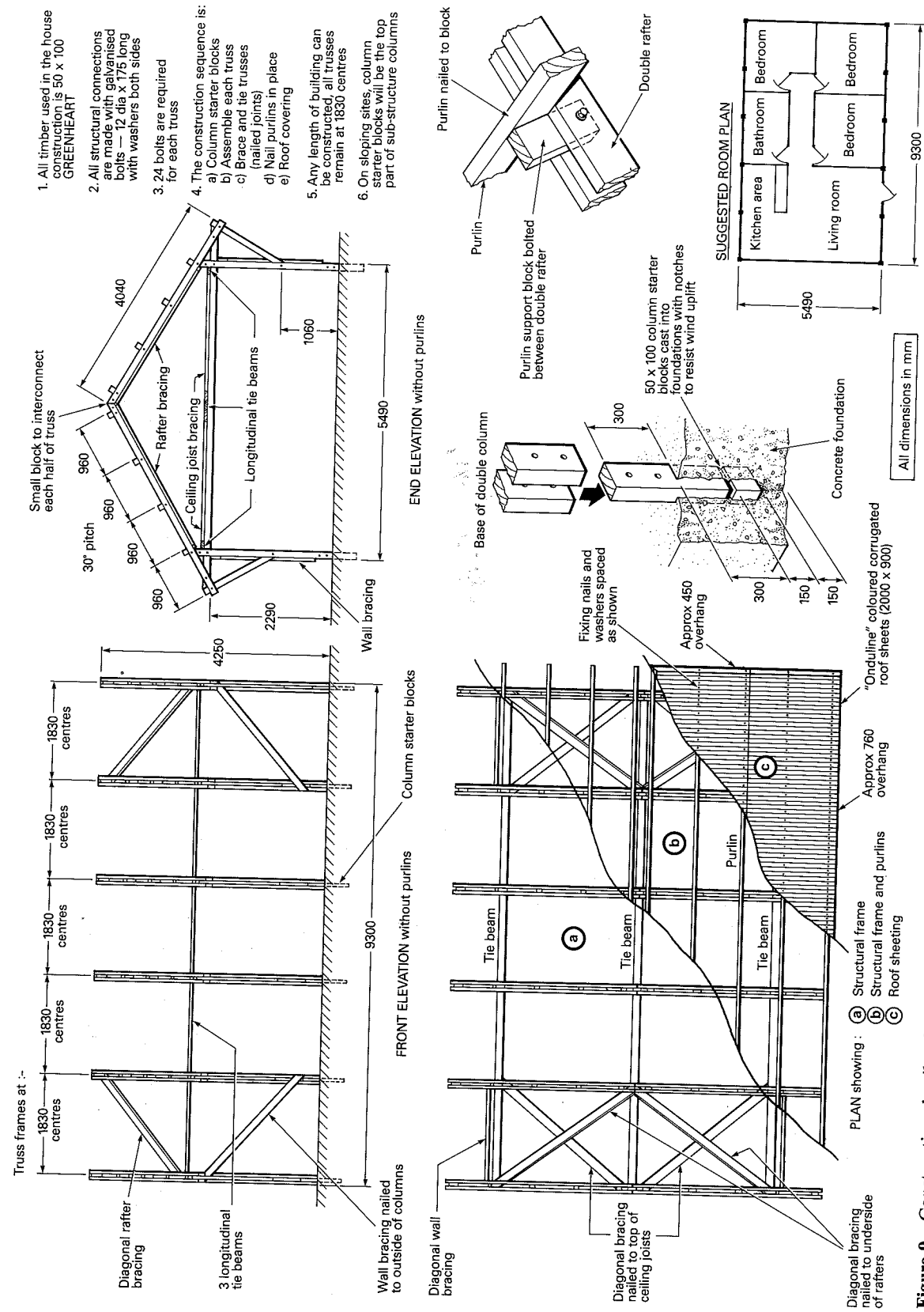

Figure 9 Construction details of St Vincent low-income house/community building

Subsequently, a fourth design was developed and a trial house constructed (Figures 8 and 9). The main features of this design are the structural strength, ie resistance to earthquakes and hurricanes; the low cost and ease of construction — permitting considerable prefabrication with the frames assembled in a jig; the use of single-size timber (50 × 100 mm) and single-size bolted joints throughout; a wide clear span up to 6.1 m, and unlimited length providing a building capable of many uses from single-family housing to community buildings such as schools and medical centres.

As well as the work on St Vincent, BRE provided assistance on the island of Dominica following hurricanes 'David' and 'Frederick' in 1979 which caused severe damage with winds gusting to 66 m/s. In particular, help was given in assessing the extent of the damage and rebuilding costs as well as providing detailed technical advice on improved methods of construction.

Similar help and technical advice was also provided by BRE to the authorities in St Lucia following hurricane 'Allen' which struck the island in 1980 with winds gusting to 56 m/s. In this instance, the most severe damage was to public buildings such as schools and health centres with generally only moderate or slight damage to housing.

SOUTH PACIFIC. BRE has examined the problems associated with cyclone damage to buildings in Fiji, Tonga, Vanuatu and the Solomon Islands. Where appropriate, detailed technical advice has been given concerning risk assessment and cyclone-resistant construction methods. An example of low-cost cyclone-resistant building design suitable for single family housing was demonstrated to the Fiji Housing Authority using a scale model. This was based on experience gained in the Caribbean, the structure being a development of the St Vincent low-income house/community building (Figure 8) modified to meet specific housing requirements in Fiji (Figure 10).

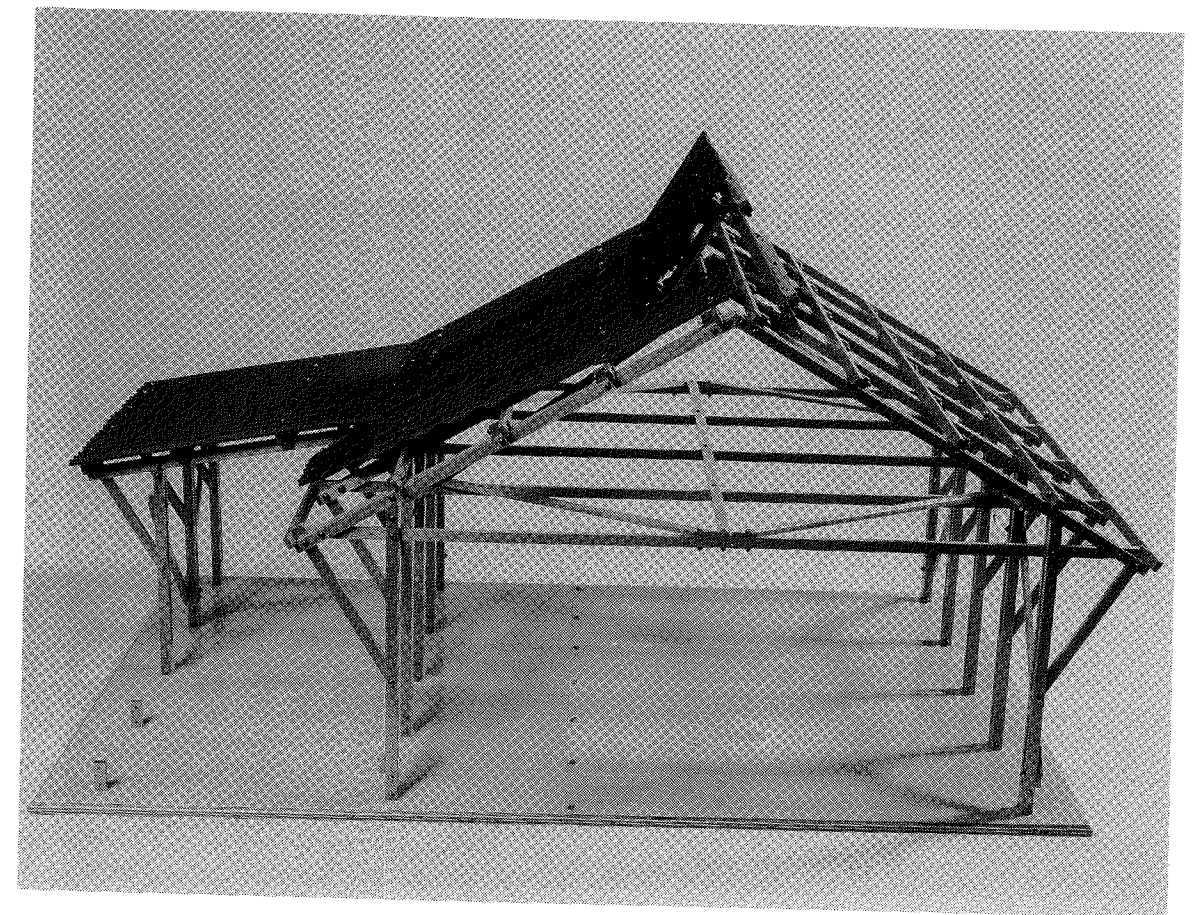

Figure 10 Model of Fiji house with high-aspect roof and side extension

BRE also assessed the damage caused by cyclone 'Oscar' which struck Fiji in March 1983 with wind speeds of 51 m/s. In the vicinity of Nadi town on Viti Levu, several school classrooms were wrecked and other buildings in exposed areas like the airport suffered cladding damage. One hotel suffered both structural and cladding damage and many houses lost their roofs, some being completely destroyed. It was significant that the damage suffered by the traditional timber/thatch buildings was no more — and in some cases less — than that sustained by modern timber/corrugated sheet houses. Clearly, the condition of the structure and location of the building were more critical than the method of construction. As with most cyclones, damage was generally initiated by a failure of fixings in the roof, either fixings of the cladding or fixings of the roof structure. Furthermore, it was notable that in one village of timber houses none of the roofs with hipped ends failed, unlike some adjacent roofs with gable ends which suffered serious structural damage.

Following the devastation caused on islands of the Kingdom of Tonga by cyclone 'Isaac' in March 1982, a major house-building programme was undertaken using timber frame construction methods with the panels prefabricated under factory conditions (Figures 11 and 12).

The design was developed jointly by the Tongan Ministry of Works and BRE with specialised advice provided by the Cyclone Testing Station in Townsville, Queensland¹³. The walls were formed with modular panels 2.4 m long, fabricated with 50 × 100 mm studs at 600 mm centres and sheathed with plywood or fibre cement boards. The roofs were constructed with timber trusses jointed with plywood gussets or hammer-in type metal tooth plates, and clad with corrugated galvanised steel sheets. Proprietary steel straps (framing anchors) were used to fix the roof purlins to the trusses, and the trusses to the wall panels (Figure 13). Examples of the finished houses are shown in Figures 14 and 15.

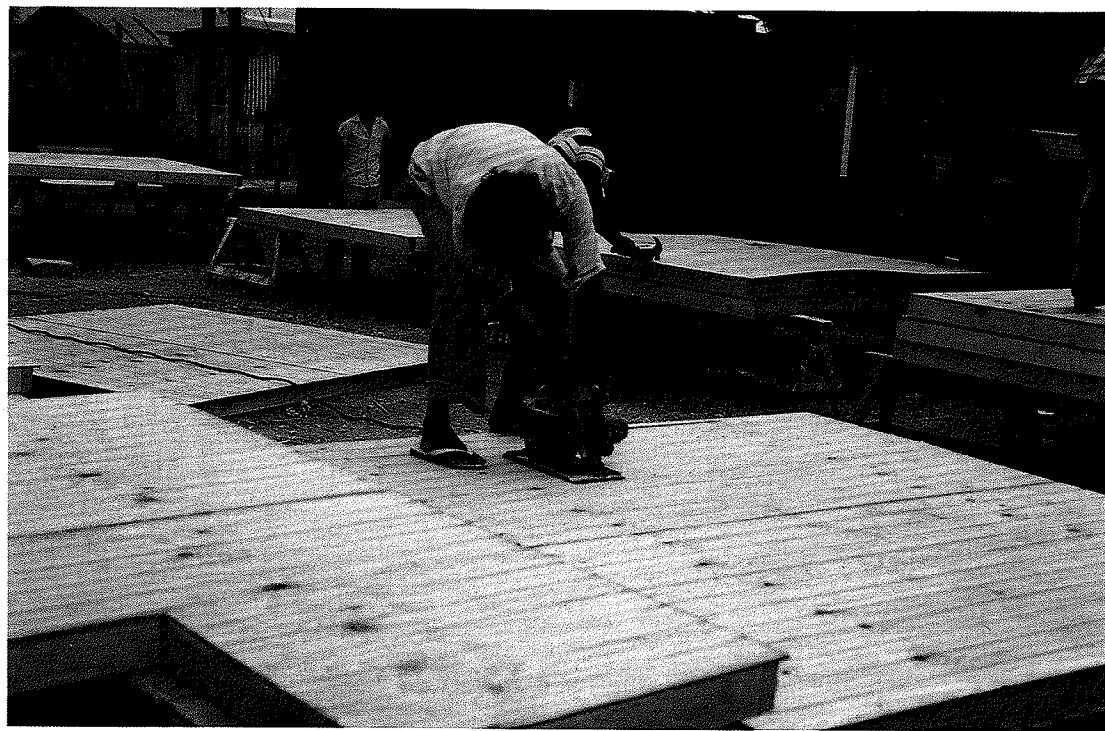

Figure 11 Factory prefabrication of Tongan housing



Figure 12 Factory prefabrication of Tongan housing



Figure 13 Construction details of Tongan house



Figure 14 Basic Tongan house with suspended timber floor on timber piles cast in concrete footings



Figure 15 Basic Tongan house with solid concrete raft ground floor

At an early stage of the house building programme, a complete kit of house components was shipped from Tonga to the Cyclone Testing Station in Queensland where it was erected using the same construction techniques as used in Tonga. A series of cyclic loading tests¹⁴ was made on this test house (Figure 16).



Figure 16 Cyclic loading tests on basic Tongan house

These tests showed that the size and location of the steel straps tying the roof trusses to the wall panels were critical details so they were replaced by a timber batten placed over the ends of the trusses and bolted through to the top plates of the wall panels. Following this modification, further tests showed that the basic house design could safely resist a simulated four-hour cyclone with wind gusts up to a design velocity of 62 m/s.

DESIGN CONSIDERATIONS

At the beginning of every building project, careful attention should be given to a range of factors to ensure that the wind forces acting on a building in a cyclone are minimised and the strength of the building structure is maximised. Factors to be considered are:

Location. Avoid building in exposed areas and on sites that are close to abrupt changes in ground level.

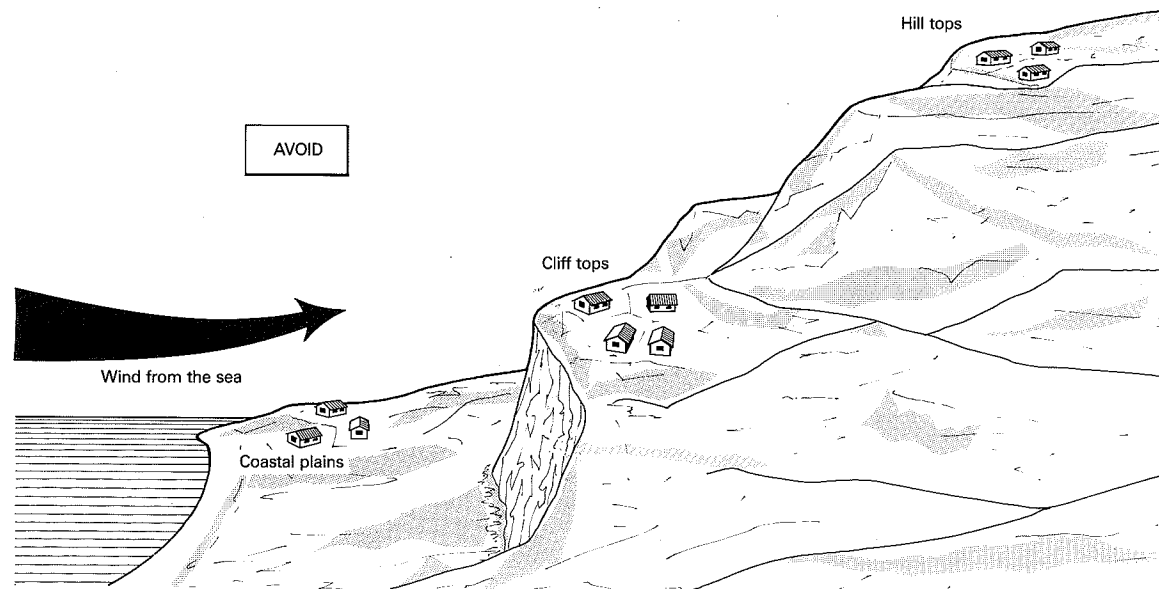

Avoid building in steep-sided valleys which open onto a beach and sea.

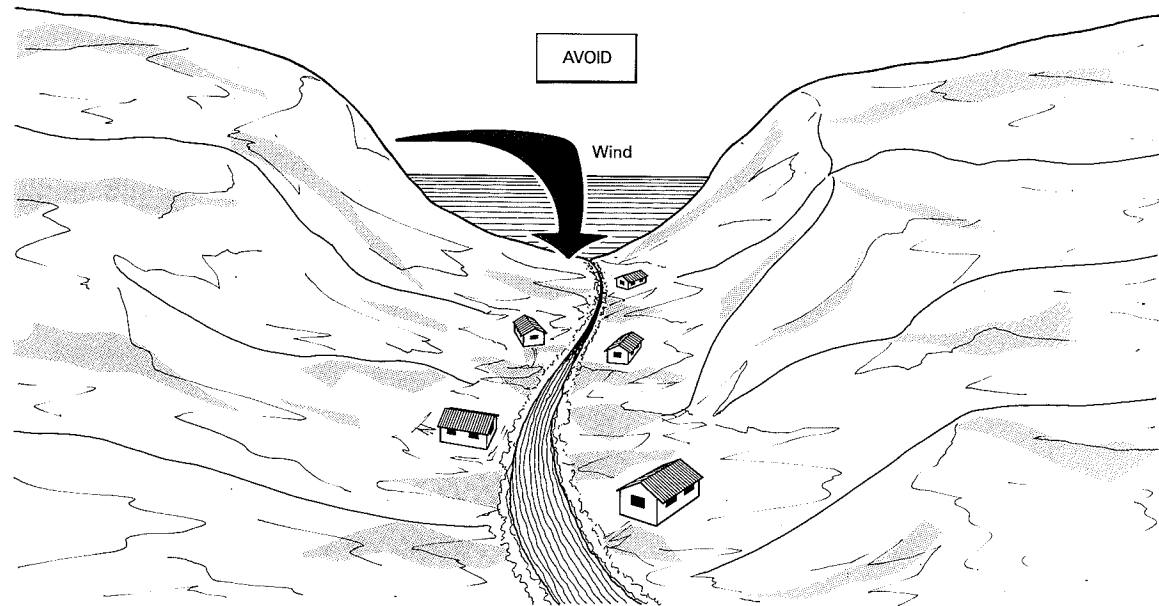

Take advantage of natural shelter provided by enclosed valleys not open to the sea, even though for some wind directions shelter will be much reduced.

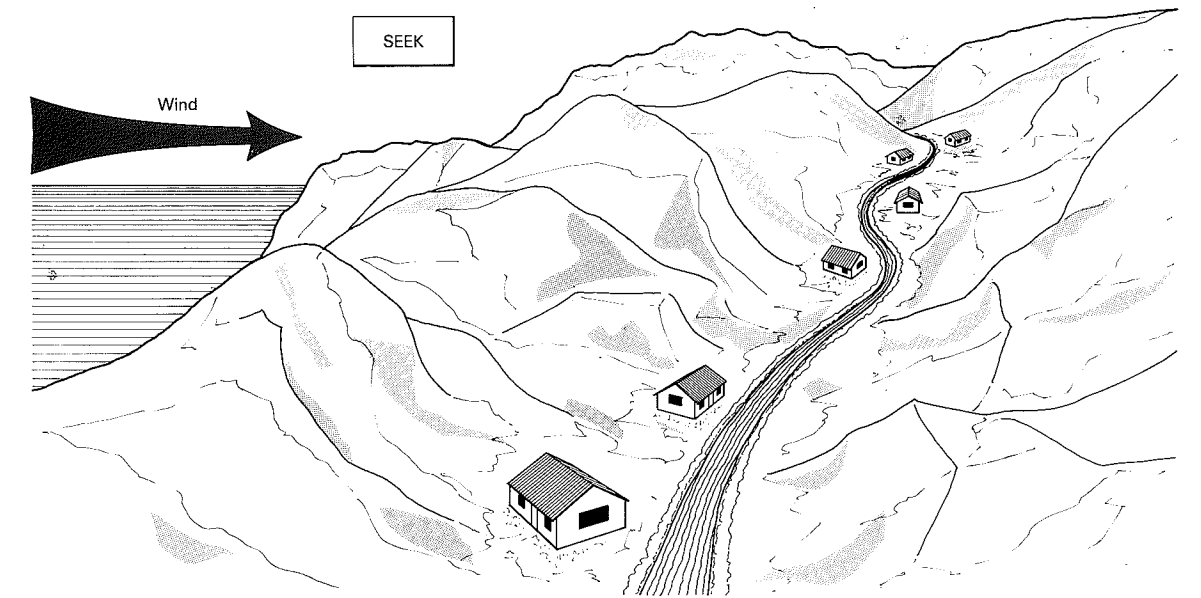

Site buildings in groups' making use of natural vegetation to provide limited but significant wind breaks.

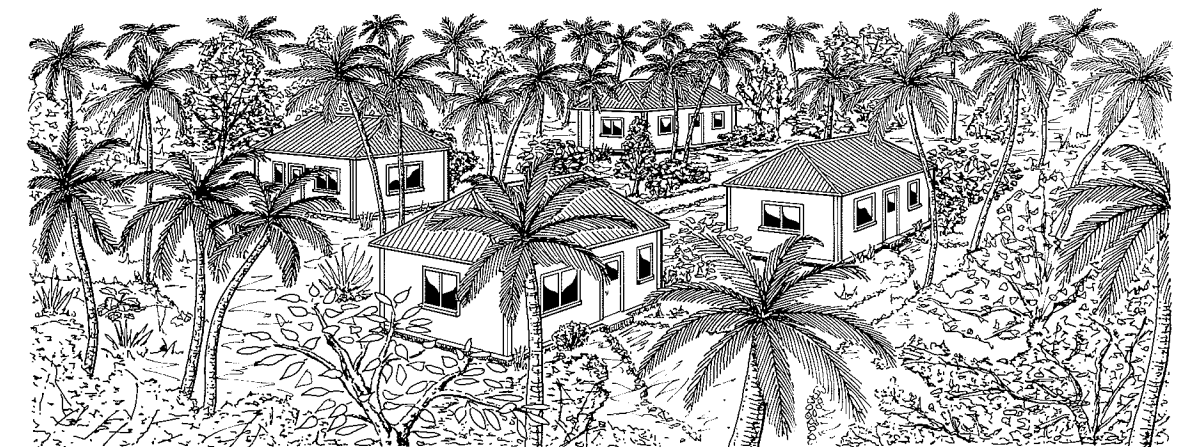

Shape. To reduce the uplift forces, build roofs with pitches between 30° and 40° and if possible provide high-level ventilation at the ridge. When possible, use hipped ends rather than gable ends.

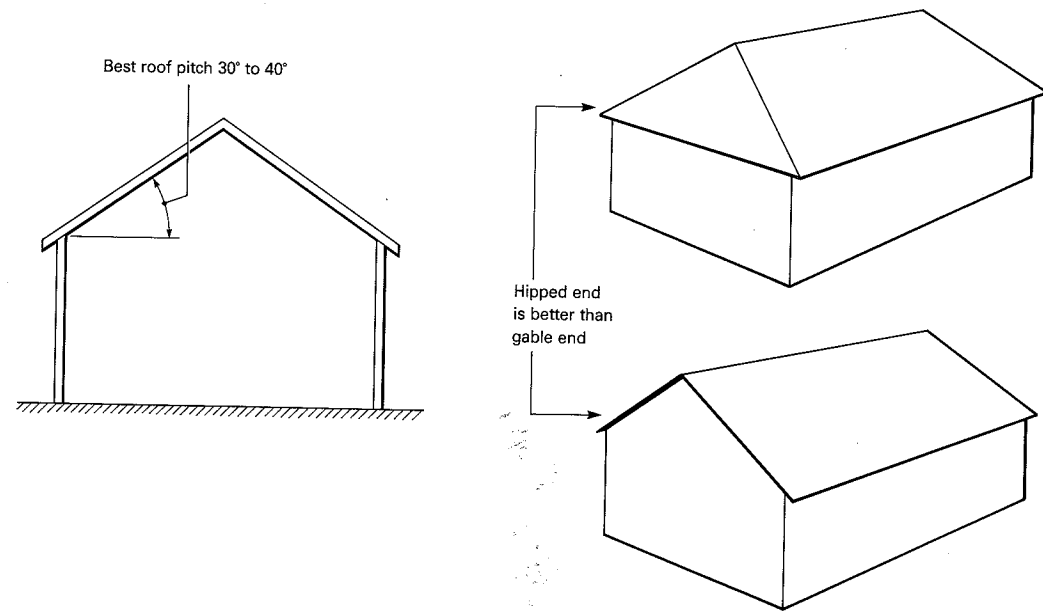

Restrict unsupported eaves overhangs to not more than 800 mm from the wall and do not notch rafters over walls by more than one-quarter of the rafter depth.

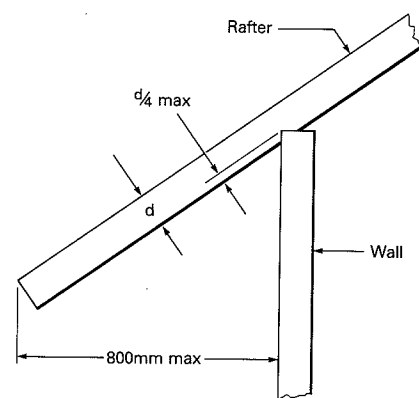

Openings. To minimise the reduction in strength caused by openings in walls for doors and windows, openings should not be positioned close to corners, the eaves or the floor.

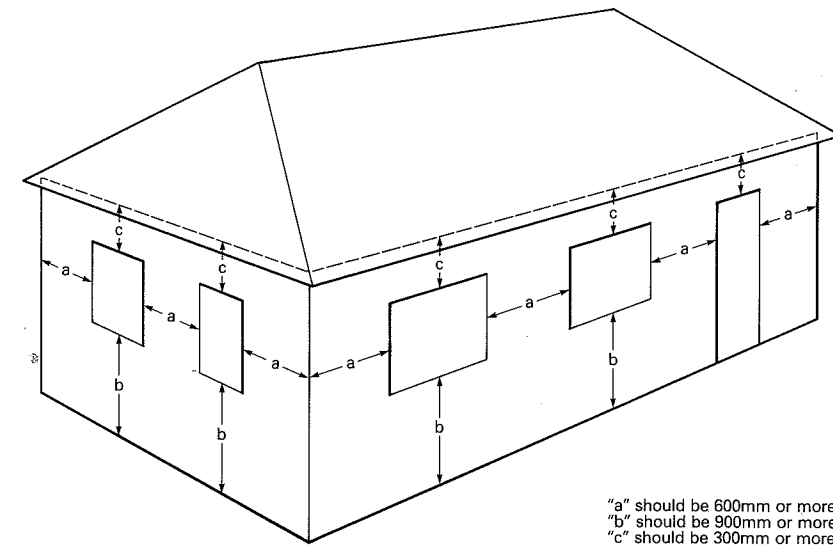

"a" should be 600mm or more
 "b" should be 900mm or more
 "c" should be 300mm or more

For each wall, the sum of the lengths of wall between openings (ie dimension 'a' should be not less than half the overall length of the wall.

Keep the size of windows as small as possible in the most exposed walls, eg those facing seaward, and position doors in other walls.

During cyclones, secure all windows and cover with removable or hinged shutters to avoid damage and prevent the build-up of high internal pressures.

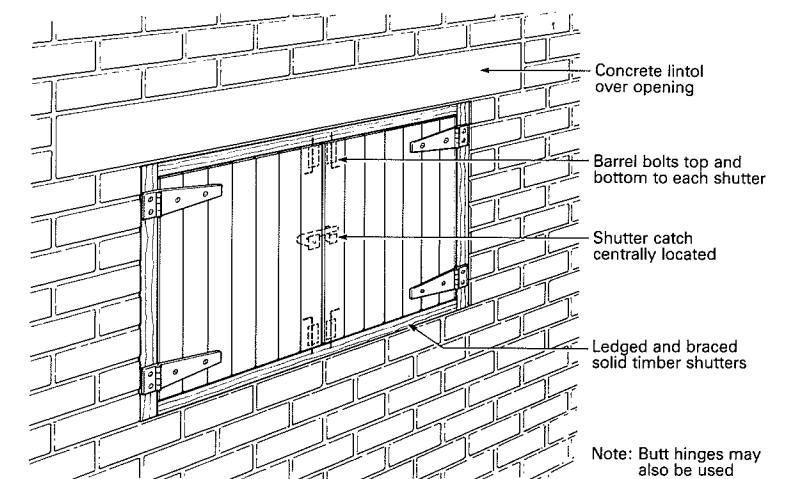
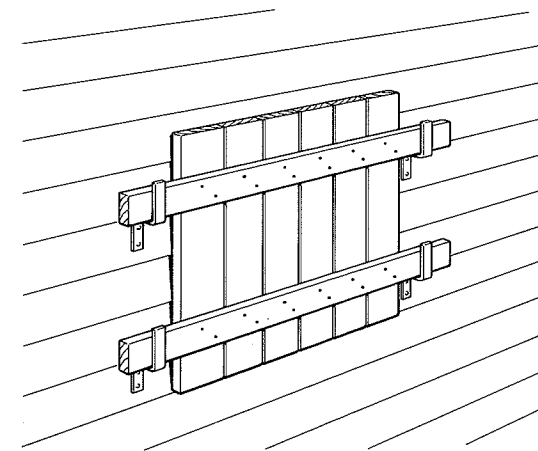

CONSTRUCTION DETAILS

To ensure buildings have maximum resistance to cyclone-force winds:

- 1) Securely fix walls together at the top, middle and bottom at all corners and intersections.
- 2) Tie down the roof structure to the top of the walls at the bottom end of every rafter.
- 3) Make sure all walls are firmly fixed down to the foundations at frequent intervals along their length.

Foundations. For masonry walls use concrete strip footings and hollow masonry blocks filled with concrete to 150 mm above floor level. The concrete should be 1 part cement to 3 parts fine aggregate (sand) to 6 parts coarse aggregate.

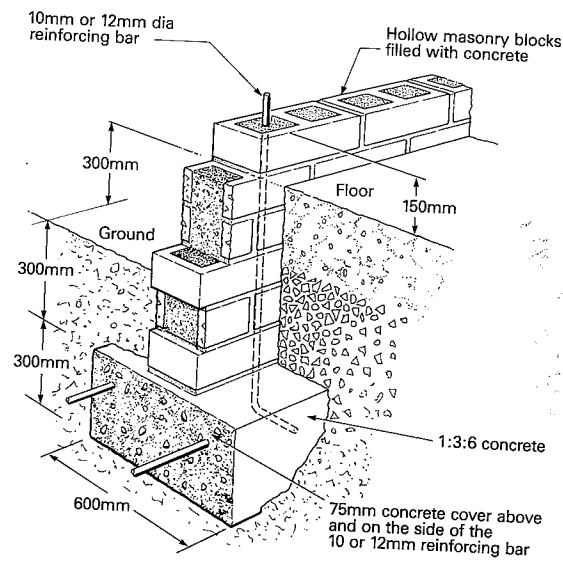

Reinforcing bars should be positioned at every corner and intersection between walls, near each side of every door and large window opening and at intermediate positions not more than 1.2 m apart. For timber-panel walls, use foundations similar to those for masonry walls but use 12 mm diameter threaded steel bar instead of reinforcing bars and bolt the timber sole plate down tight to the masonry. These hold-down fixings should be positioned at every corner and intersection between walls, near each side of every door and at intermediate positions not more than 600 mm apart.

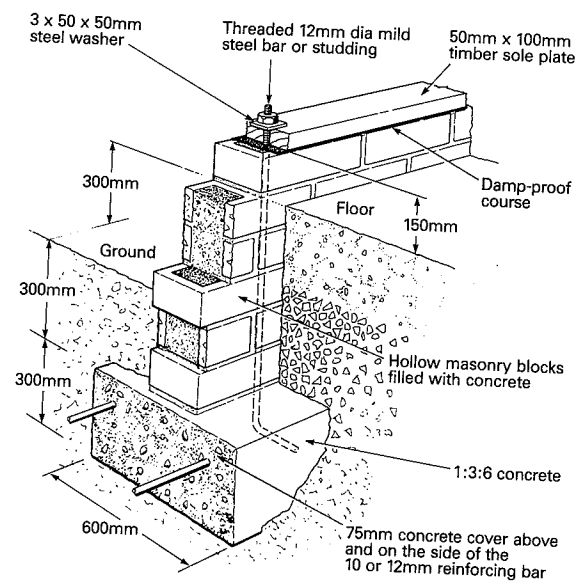

When timber columns are cast in situ in concrete foundations, use timber with good natural durability or treat the foot of the column with preservative. The foot of each column should be notched to a depth of 25 mm to form a key to resist uplift.

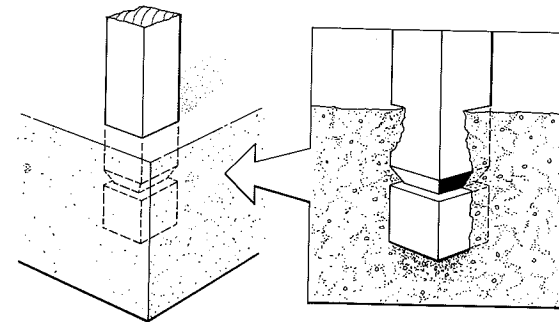

Alternatively, steel brackets can be cast into the concrete to support the foot of each timber column which should be bolted into the brackets with two 12 mm diameter bolts. This method should be used for timber columns with moderate or low durability.

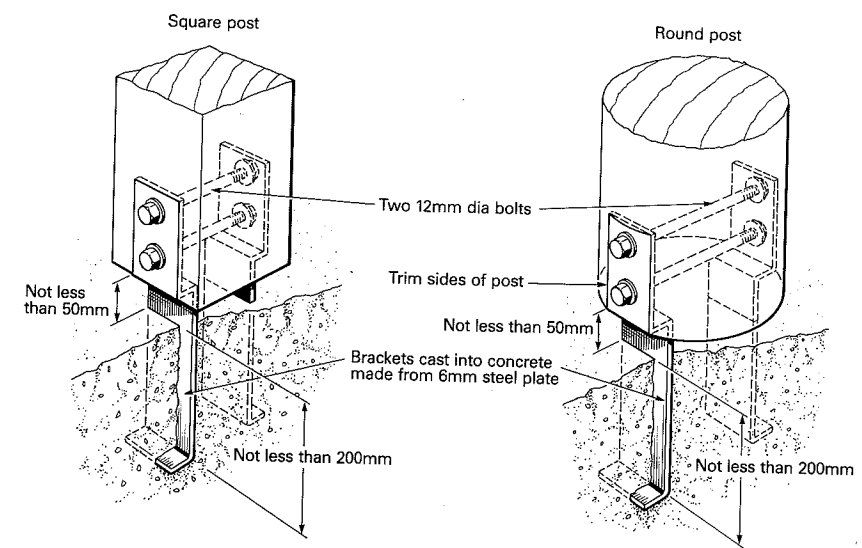

On sloping ground, support the timber floor on braced timber columns set in concrete in the ground. The spacing of the columns should be 3 m or less and the height of any column between the top of the concrete and the underside of the floor joists should be not more than 2 m.

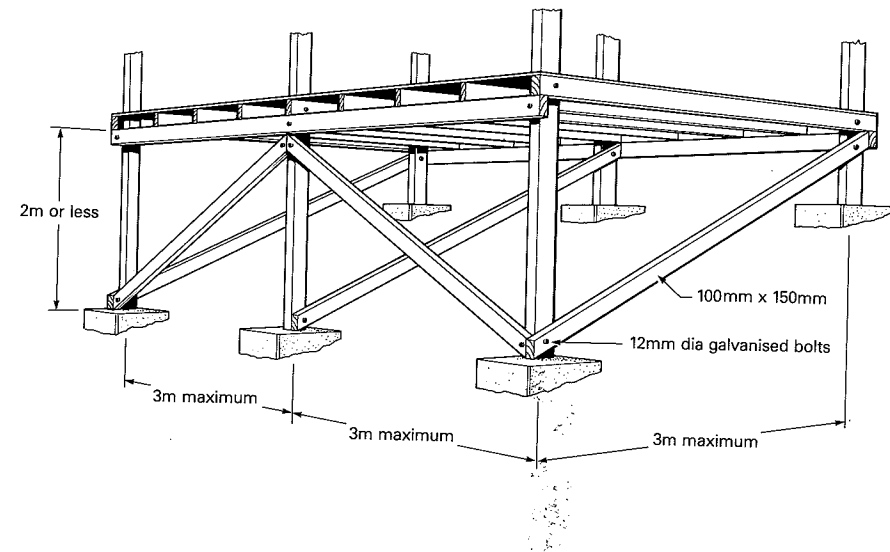

Floor. This may be of solid construction using stabilised soil or concrete or it may be of suspended timber joists with boarding. Every joist must be securely tied down to the foundations either by:

- (1) bolting down the bottom rail of the timber wall panel on top of the joists, with studding cast into the concrete footings, or —

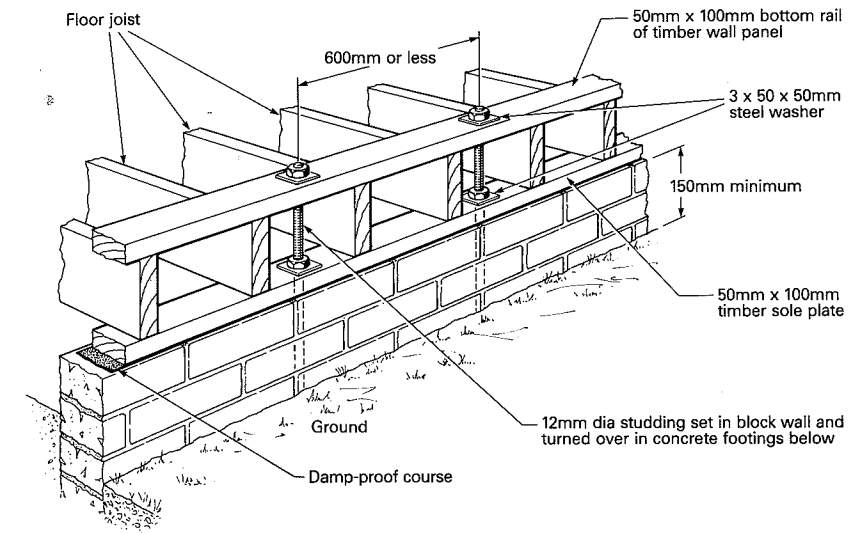

- (2) by fixing to the wall plate with metal framing anchors or galvanised metal straps.

NOTE: Make sure the wall plate is firmly fixed to the foundations.

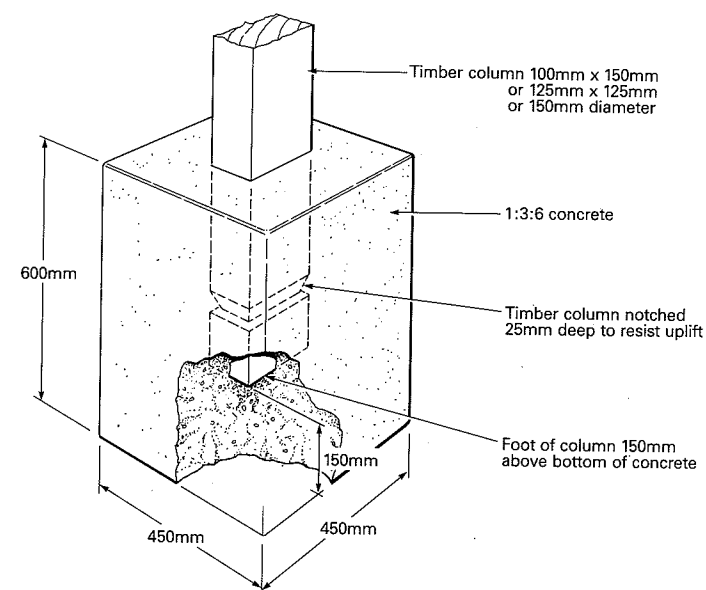
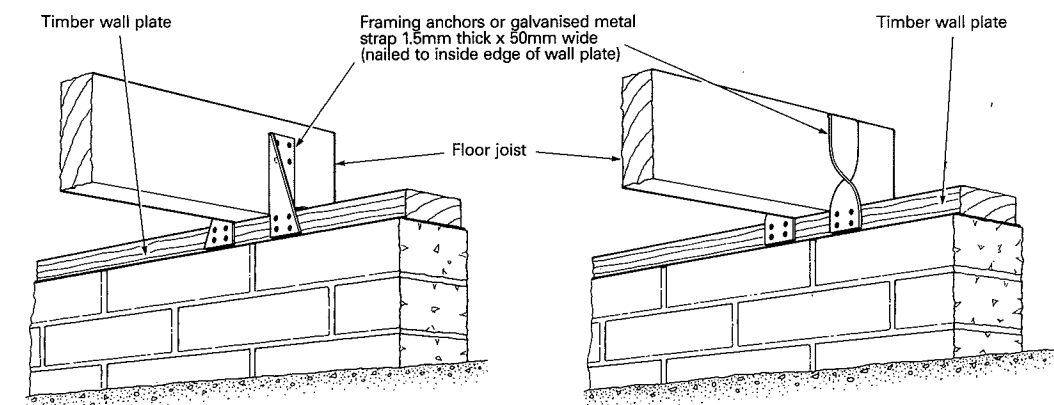

Walls. All masonry walls must be reinforced at all corners and junctions as well as at the sides of the doors and window openings. On long walls without junctions or openings, reinforced sections should be constructed at intervals of not more than 1.2 m for hollow block walls and not more than 2.0 m for solid block walls.

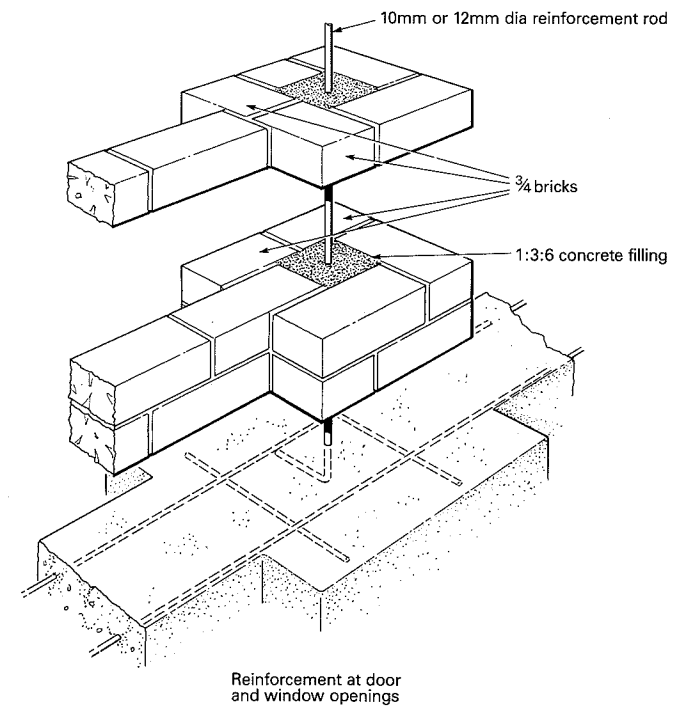
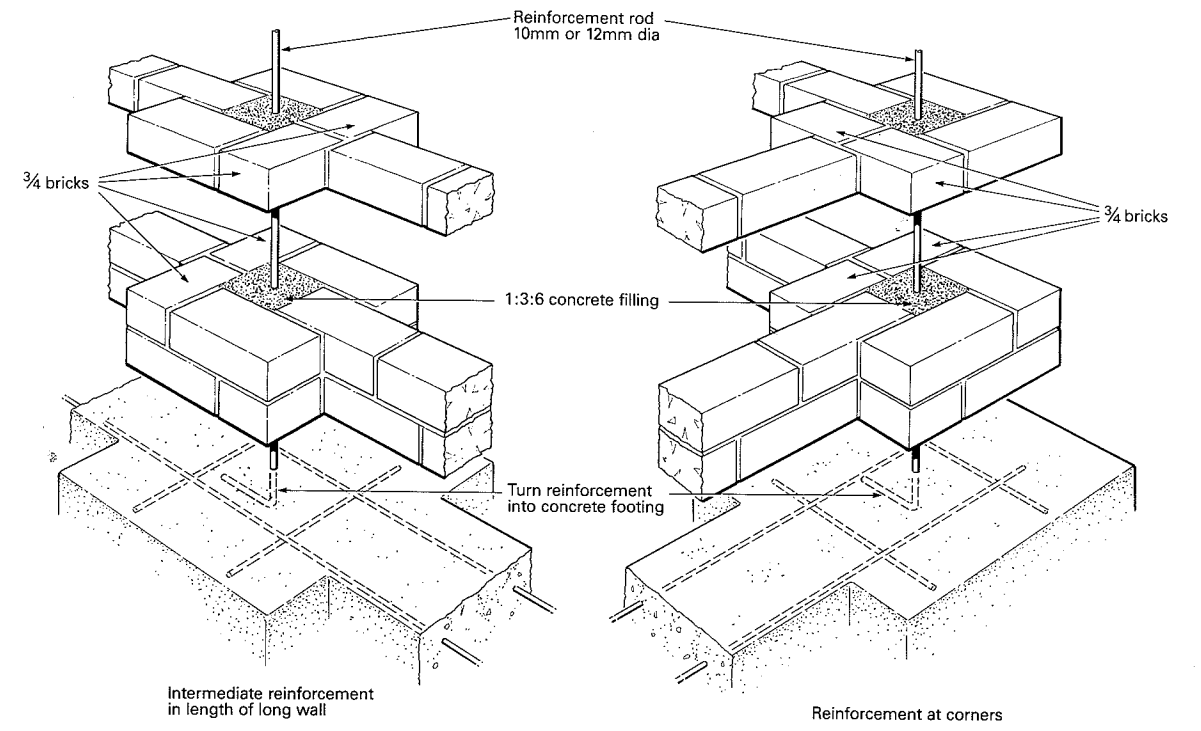
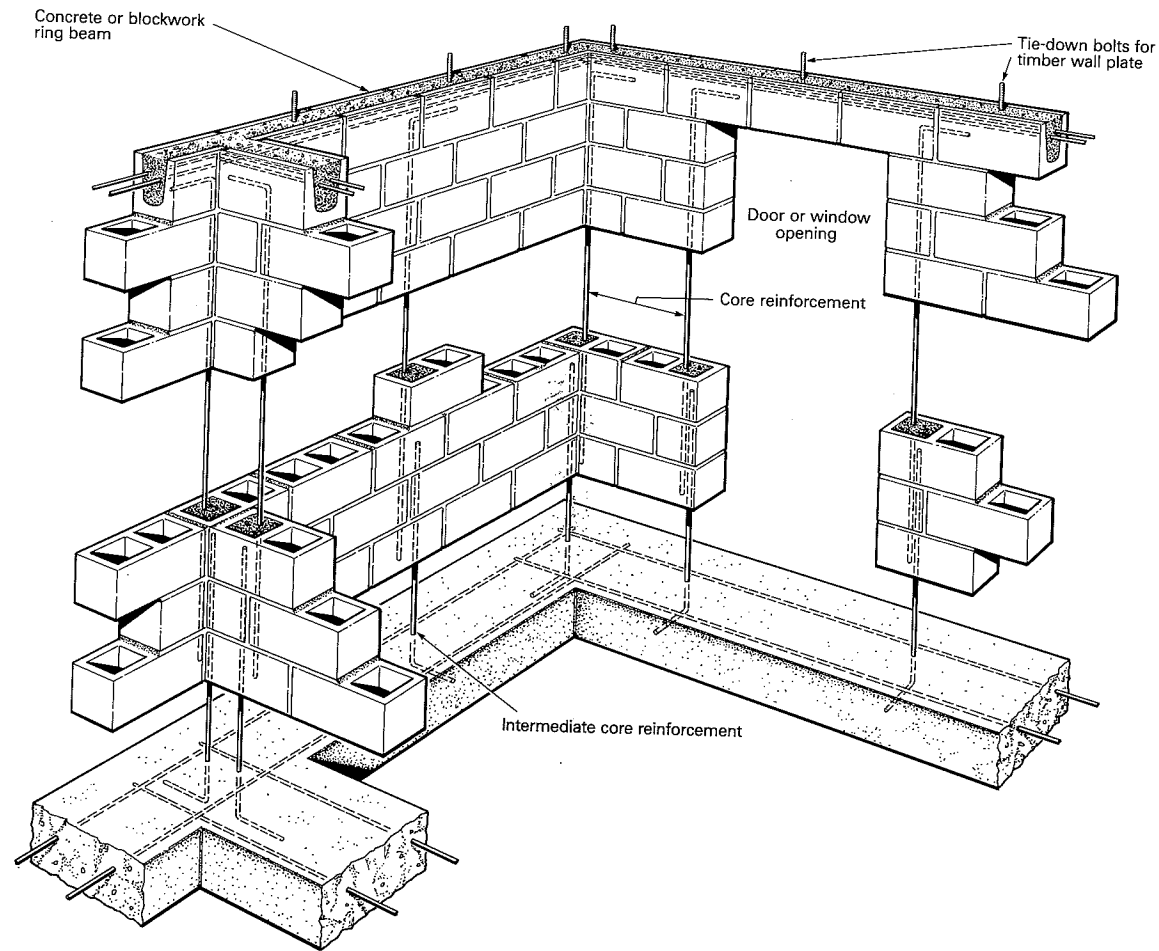

For timber-framed walls, ensure that the bottom rail of every wall panel is securely fixed down to the floor joists, sole plate or concrete foundation with galvanised metal straps, framing anchors or bolts. In addition reinforce every joint in each wall panel frame with metal strapping.

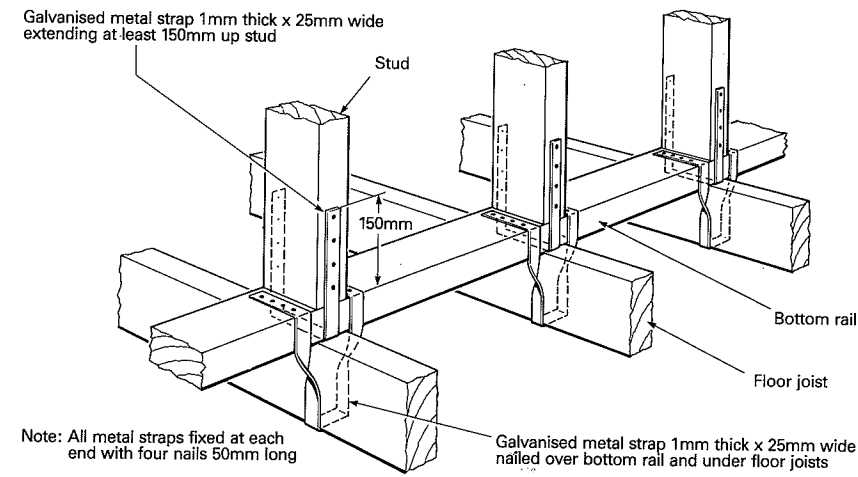

Note: All metal straps fixed at each end with four nails 50mm long

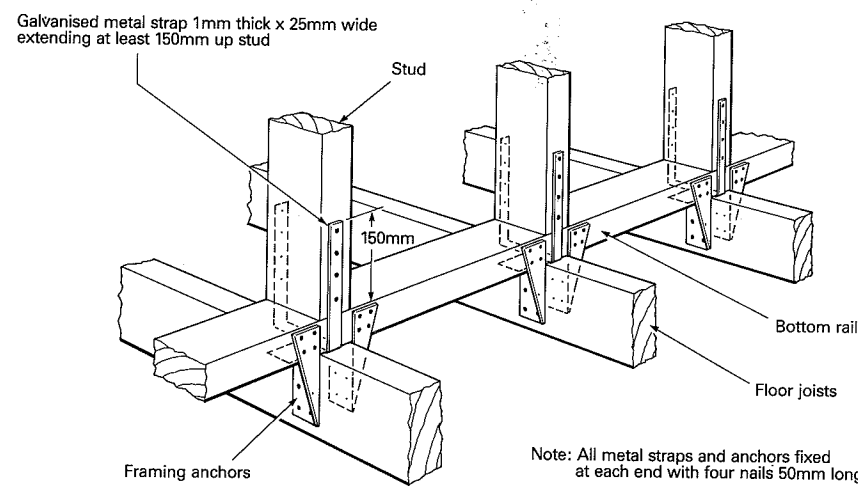

Note: All metal straps and anchors fixed at each end with four nails 50mm long

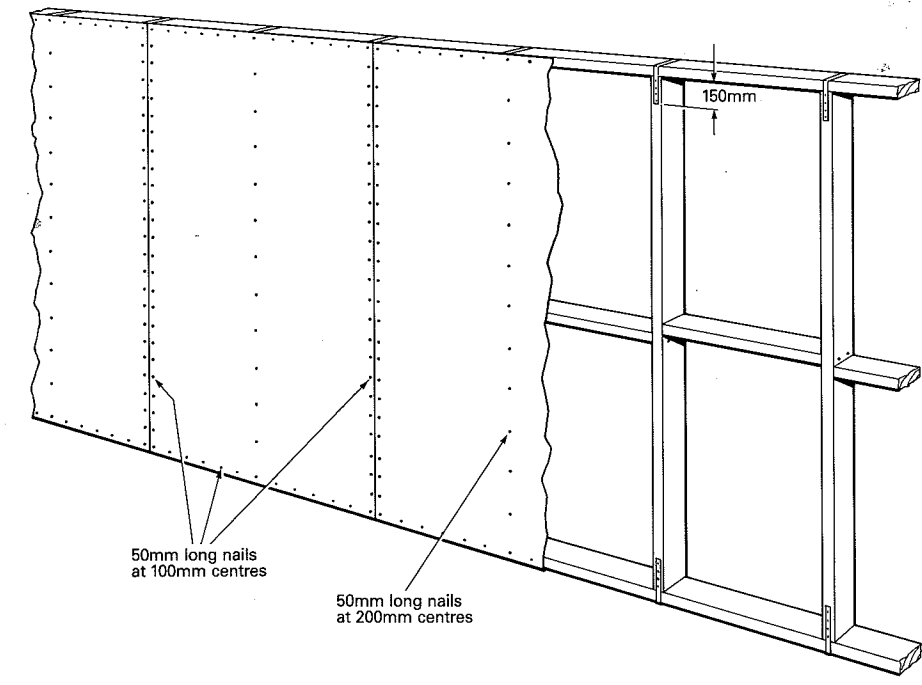
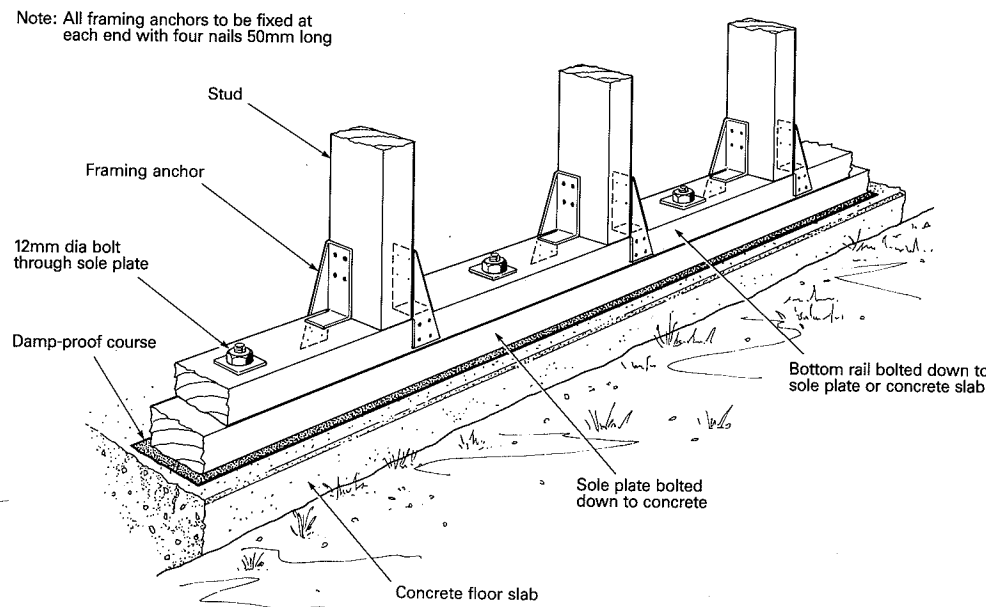

Unless timber-framed walls are fully sheathed with well nailed rigid boarding such as plywood or similar, they should be fitted with diagonal timber braces let into the framing.

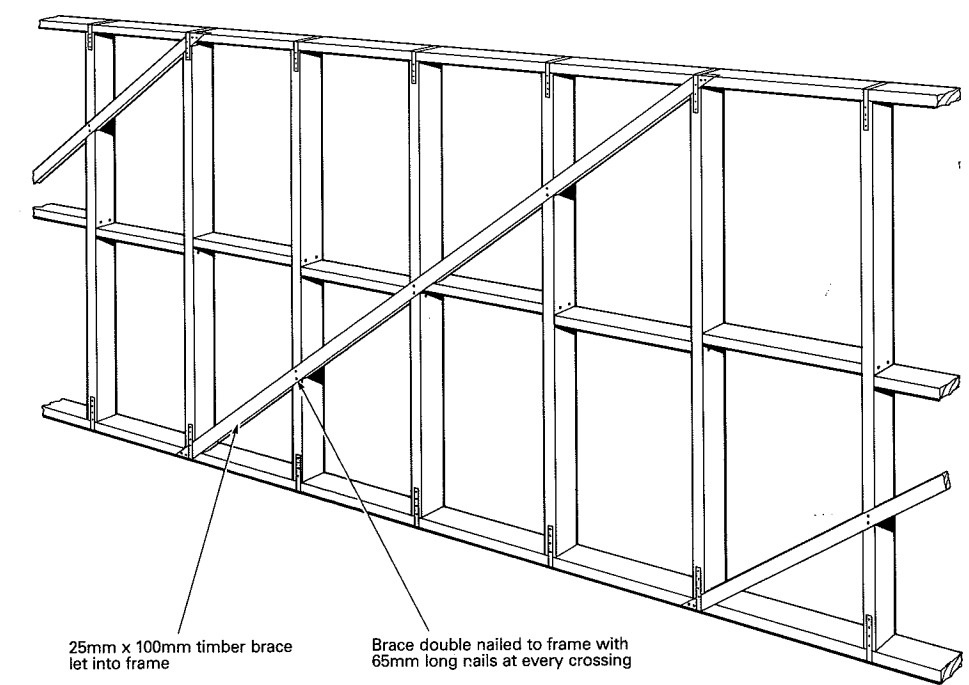

Roof. It is essential that all the structural members in a roof, eg rafters, ridge board and purlins, are securely fixed together with metal straps or timber braces. Particular attention should be paid to the arrangement of fixings to ensure that they can adequately withstand large uplift forces on the roof.

For the same reason, the whole roof structure must be firmly tied down to the timber frame or masonry walls with metal straps or bolts and diagonal timber braces should be nailed to the undersides of the rafters at each end of the roof to prevent sideways movement.

Rafter to timber frame wall connections

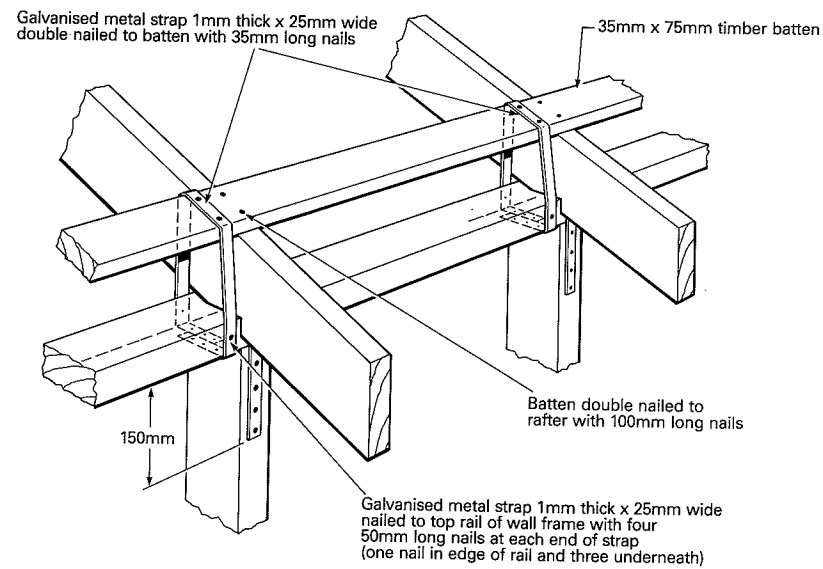
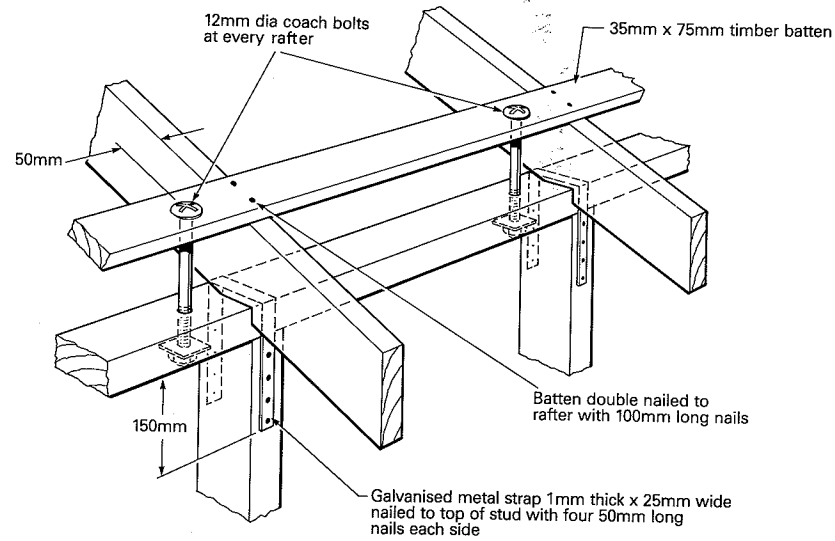

Rafter to masonry wall connections

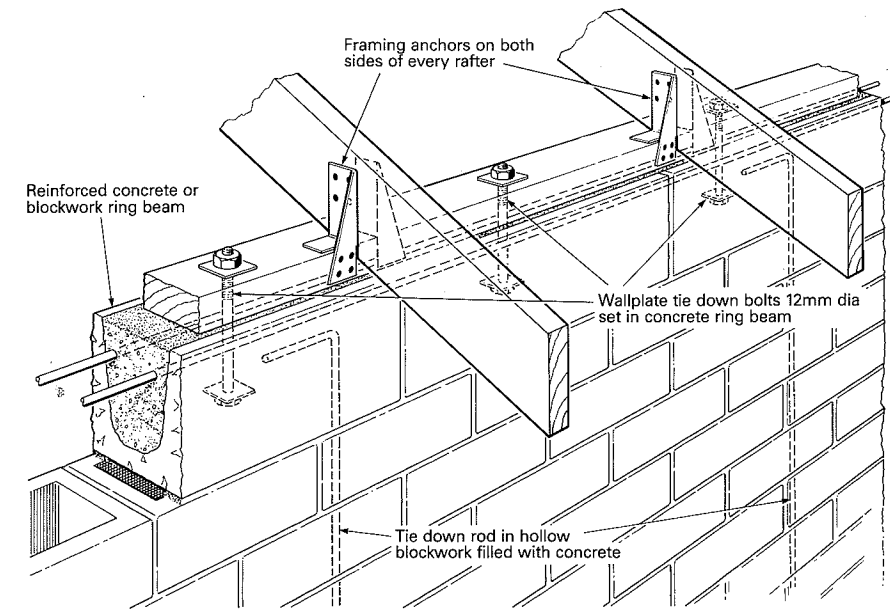

Purlin to rafter connections

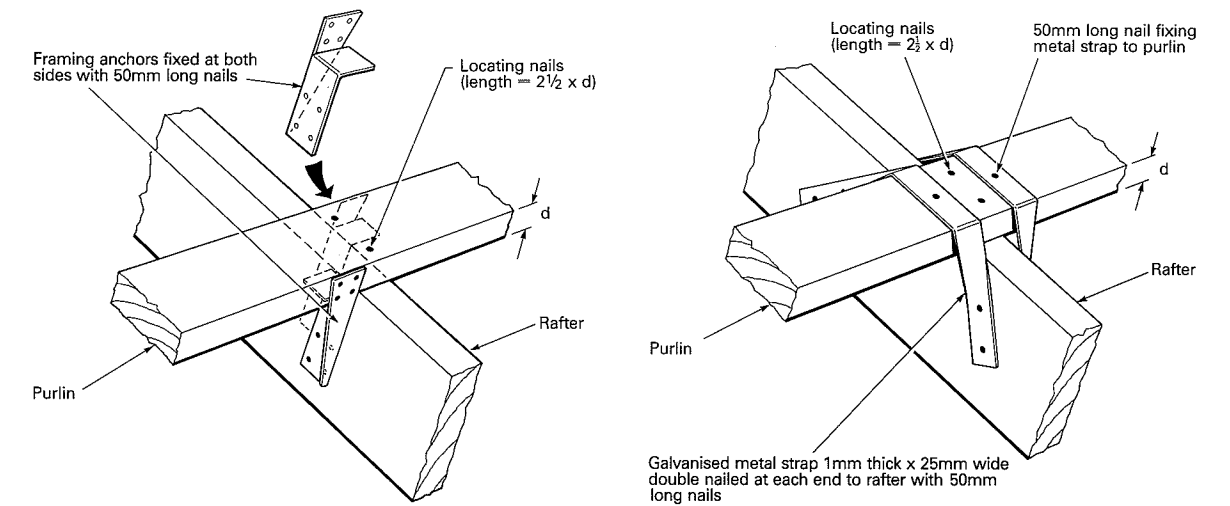

Rafter to ridge board connections

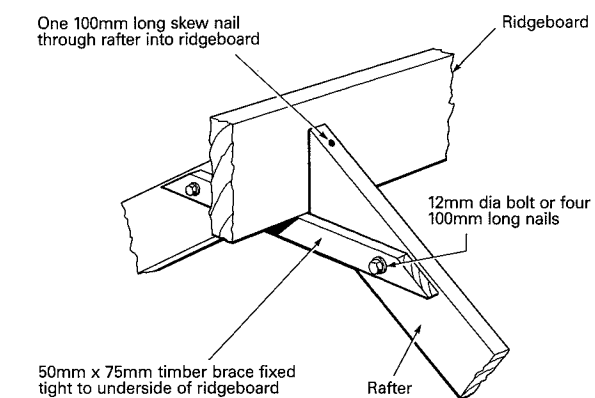

Rafter bracing

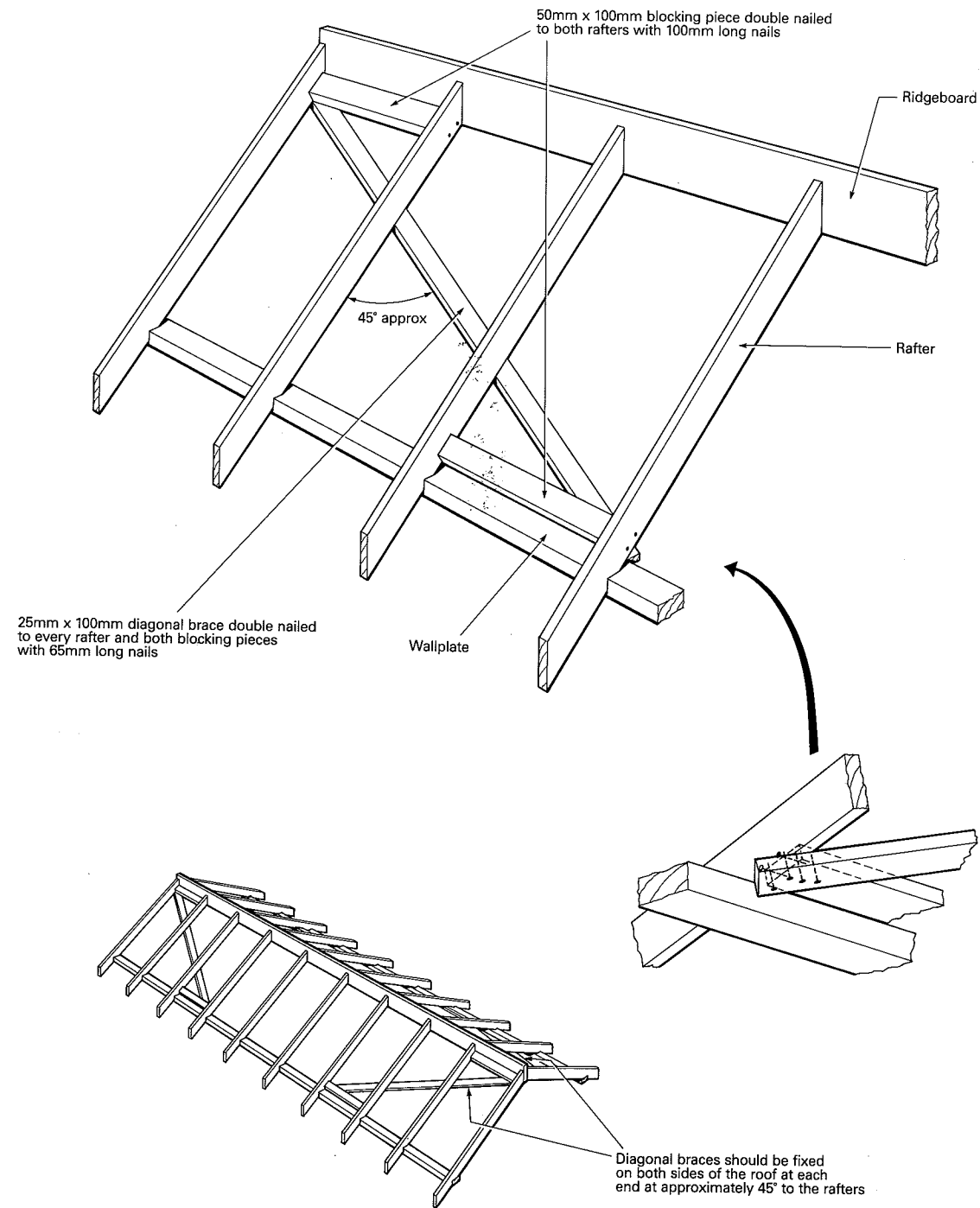

Where lightweight corrugated roofing sheets are used to cover a roof, every sheet should be securely fixed down to the purlins with galvanised hook bolts or special square twisted roofing nails. Particular attention should be given to the edges of a roof where wind uplift forces are greatest and fixings should be more frequent to prevent roofing sheets being 'peeled back'.

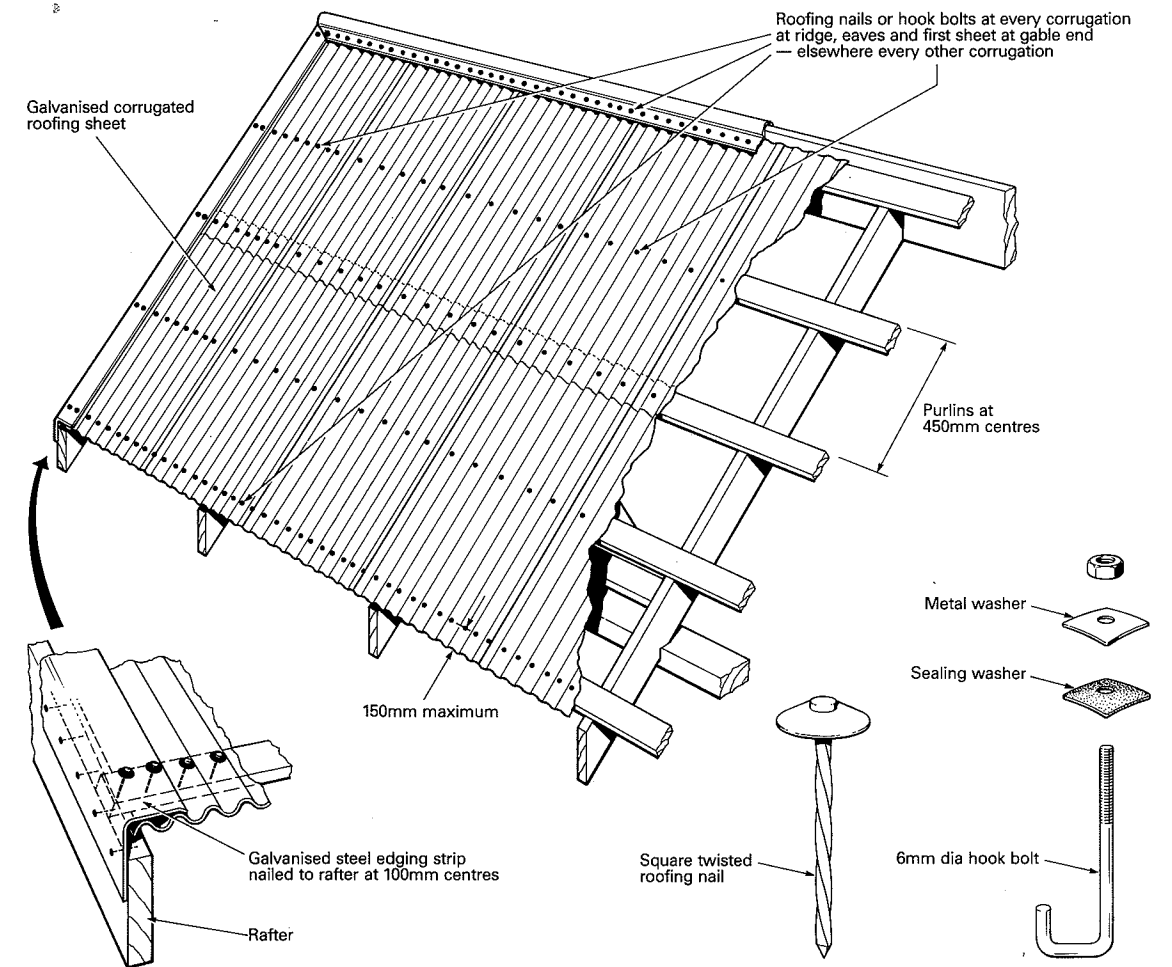

MAINTENANCE FOR OCCUPIERS

Once a house has been built, it requires regular attention to maintain it in good order. Some features should be checked regularly:

- (1) Latches and catches on doors and windows must always work properly so that the doors and windows can be closed and secured when a cyclone is expected.
- (2) Loose shutters to cover windows should always be readily available and the brackets to support them on the walls must be kept unobstructed and securely fixed. Similarly, hinged shutters should be kept unobstructed and free so that they can be closed and securely fastened.
- (3) Where access is possible, all bolted joints, nail fixings and metal straps should be checked for tightness. This is particularly important during the first year after construction when timber members may shrink and twist.
- (4) Fixings for lightweight roof sheeting should be checked to see if they have vibrated loose, particularly round the edges of the roof and at the ridge.
- (5) The ground level next to the external walls should be kept at least 150 mm below the internal floor or the walls may become damp on the inside and lead to rot in timber or corrosion of metal. Similarly, storage of objects outside against the walls should be avoided and vegetation close to the walls should be kept low.
- (6) The sources of any leaks appearing in the walls or roof should be found and strong, sound waterproof repairs carried out immediately on the outside. Rot in timber members and corrosion of metal straps, bolts and nails may result if this is not done.

When making modifications or adding extensions to houses, it is important to avoid weakening the existing structure. Do not position new door or window openings near corners or close under the roof eaves and do not remove any of the original external walls.

Regular attention to the items listed above, together with the speedy repair of any defects which do occur, will help to ensure that the house remains weathertight and best able to withstand high wind forces with a minimum amount of damage.

FURTHER ASSISTANCE

The extensive information and expertise existing at BRE concerning the provision of cyclone-resistant low-cost housing is available to assist developing countries. There may be areas of the world where further work is required to assess local conditions and resources, in order to find the most effective ways of providing cyclone resistance.

Organisations seeking advice or collaborative work should contact the Overseas Division, Building Research Establishment, Garston, Watford, WD2 7JR, United Kingdom.

REFERENCES

- 1 **Crutcher H L and Quayle R G.** *Mariners worldwide climatic guide to tropical storms at sea.* US Naval Weather Service Command, NAVAIR 50-1C-61, March 1974.
- 2 **Building Research Establishment.** The assessment of wind loads. *BRE Digest 119*, Garston, Watford, UK, 1984.
- 3 **Building Research Establishment.** The assessment of wind speed over topography. *BRE Digest 283*. Garston, Watford, UK, 1984.
- 4 **Building Research Establishment.** Wind loads on canopy roofs. *BRE Digest 284*, Garston, Watford, UK, 1986.
- 5 **Cook N J.** The designer's guide to wind loading of building structures. Part 1: Background, damage survey, wind data and structural classification. Butterworths, Sevenoaks, UK, 1985.
- 6 **Eaton K J.** Buildings and tropical windstorms. *BRE Overseas Building Note No 188*, Garston, Watford, UK, 1981.
- 7 **Walker G R and Eaton K J.** Application of wind engineering to low rise housing. *Proc 6th International Conf on Wind Engineering.* 1983.
- 8 **US Department of Commerce, National Bureau of Standards.** Building to resist the effect of wind.
Vol 1 Overview.
Vol 2 Estimation of extreme wind speeds and guide to the determination of wind forces.
Vol 3 A guide for improved masonry and timber connections in buildings.
Vol 4 Forecasting the economics of housing needs: A methodological guide.
Vol 5 Housing in extreme winds: Socio-economic and architectural considerations. *NBS Building Science Series 100*, Washington DC, 1977.
- 9 **Lam L C H, Lam R P and Mackey S.** Full-scale measurement of wind pressure fluctuations on a bluff building. *Proc 5th International Conf on Wind Engineering*, 1979.
- 10 **Ministry of Local Government, Housing and Construction.** Design of buildings for high winds. Colombo, Sri Lanka, 1980.
- 11 **Eaton K J.** Low income housing and hurricanes. *Proc 5th International Conf on Wind Engineering*, 1979.
- 12 **Eaton K J.** Hurricane resistant low-income housing. *Building Research and Practice*, Nov/Dec 1982.
- 13 **Eaton K J and Reardon G F.** *Cyclone housing in Tonga.* Building Research Establishment, Garston, Watford, UK, 1985.
- 14 **Reardon G F, Boughton G N and Eaton K J.** Structural testing of a Tongan hurricane house. *Proc CIB/W-73 International Conf on Natural Hazards Mitigation Research and Practice: Small Buildings and Community Development*, 1984.

Cyclone-resistant houses
for developing countries

113815

8.00

BR 131

ISBN 0 85125 292 3

BRE