

IMPROVEMENT OF RURAL HOUSING IN HAITI
TO WITHSTAND HURRICANES

Frederick C. Cuny

Drawings by A. James Viets and Juliana Marek

INTERTECT
P.O. Box 10502
Dallas, Texas 75207

September 1982

This report was prepared under a contract from the
OXFAM Regional Office for the Caribbean for the consideration
of the Haitian PVO Disaster Preparedness Committee (formed by
representatives of the Red Cross, OXFAM, CRS, Caritas and CARE).

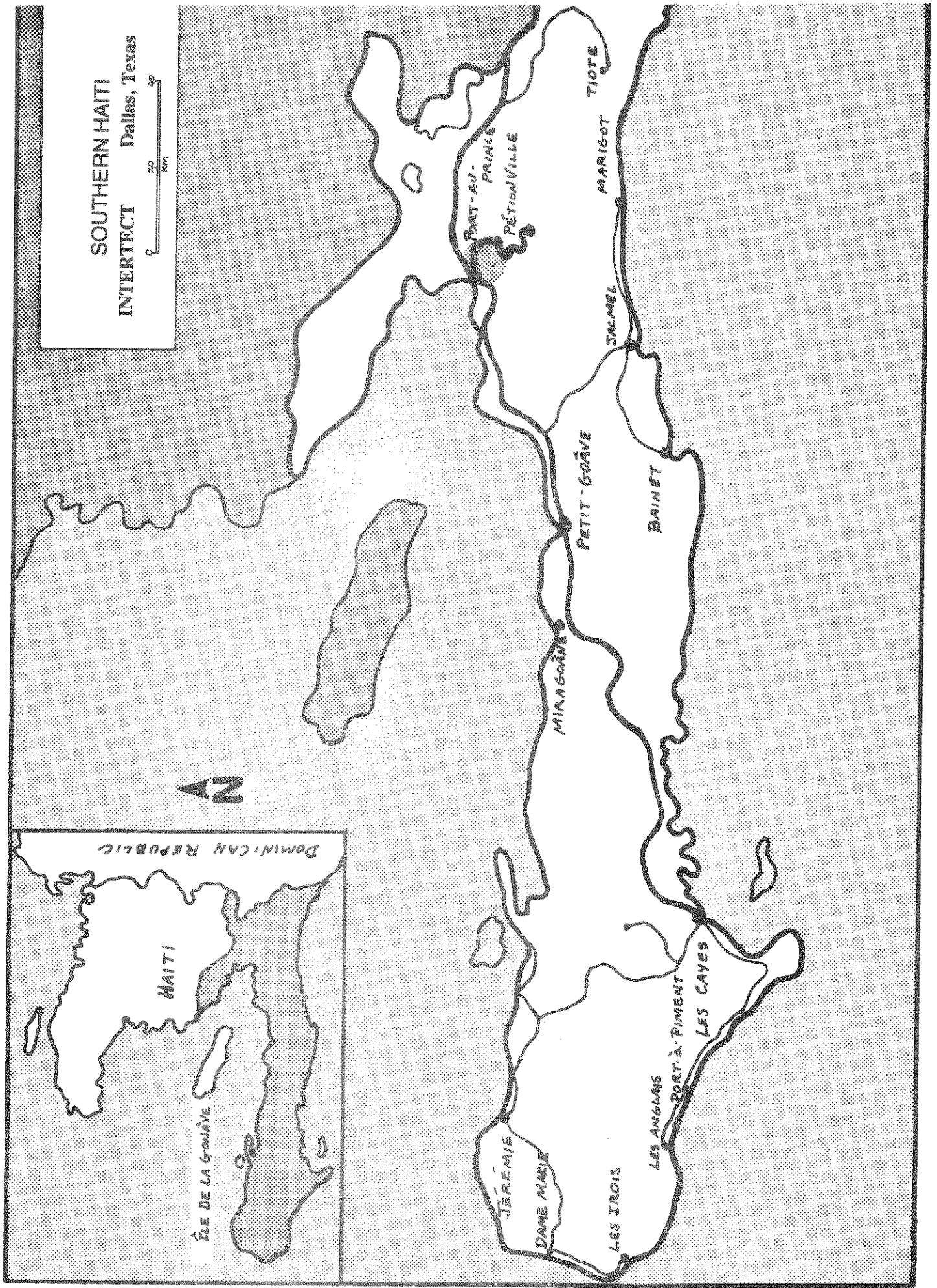

FIGURE 1

TABLE OF CONTENTS

	<u>Page</u>
Acknowledgments	iv
Glossary of Terms	v
I. INTRODUCTION	1
Background	1
The Importance of Housing Improvement	2
II. RISK AND VULNERABILITY IN HAITI	6
Hurricane Risk	6
Earthquake Risk	12
Fire Hazards	12
Establishing Priority Areas for Vulnerability Reduction	12
III. GENERAL DESCRIPTION OF HOUSING TYPES	14
Basic Housing Types	14
Popular Designs	17
Roofs	19
IV. VULNERABILITY ANALYSIS OF TRADITIONAL HOUSES IN HAITI	21
What Makes Houses Safe in Hurricanes?	21
Popular Building Features	22
Vulnerability Analysis of the Basic Construction Types	30
V. THE BUILDING PROCESS	49
The Role of the Building Tradesmen	49
Building Skills	50
Carpentry Skills	50
Stone Masonry Skills	57
Concrete Block Masonry	59
Financing	61

ACKNOWLEDGMENTS

This study would not have been possible without the support and assistance of many people. The OXFAM personnel in Haiti were extremely helpful, not only with logistics and transportation but also with advice and guidance. We were especially appreciative of the time and dedication given to this project by M. Melius Hyppolite.

The staff of CRS/Haiti was very helpful to us in the field research. Director Serge Picard and the CARITAS staff in Jérémie also offered support and assistance as we conducted research in the western region of the project area.

The author would particularly like to thank the OXFAM Regional Director for the Caribbean, Ms. Lesley Roberts. Without her encouragement and support, this project and report could not have been accomplished.

GLOSSARY OF TERMS

Following are definitions of terms used in this report:

Housing Education Program - (HEP): This term is used to denote a program offering vocational training to homeowners or builders in how to build a safer or more disaster resistant house.

Design Changes: This term refers to the process of altering the design of a structure before it is built to make it more disaster resistant.

Retrofitting: This term refers to the process of installing additional supports or altering components of a building already erected in order to make it more disaster resistant.

Housing Modification: This term refers to changing the configuration of a house after it has been built to make it more resistant. Modification could include changing the pitch of the roof, adding an extra room, etc.

Risk: Risk is the relative degree of probability that a hazardous event will occur. An active fault zone, for example, would be an area of high risk.

Vulnerability: Vulnerability is a condition wherein human settlements or buildings are exposed to a disaster by virtue of their construction or proximity to hazardous terrain. Buildings are considered vulnerable if they cannot withstand the forces of high winds or earthquakes. Communities in unprotected, low-lying coastal areas exposed to hurricanes, or in seismic areas where a large proportion of the structures cannot withstand the effects of an earthquake, are considered "vulnerable communities".

Disaster Resistant Construction: The term "disaster resistant" is used to denote the degree to which a structure can be made more resistant (or safe) to certain natural phenomena. The term recognizes that no building can be considered totally safe, but that certain steps can be taken to improve performance or survivability.

IMPROVEMENT OF RURAL HOUSING IN SOUTHERN HAITI
TO WITHSTAND HURRICANES

I. INTRODUCTION

BACKGROUND

In 1980 Hurricane Allen brushed along the southern coast of Haiti and did considerable damage to several communities. Although damage was relatively light, Allen demonstrated that the majority of housing in the area is extremely vulnerable to high winds. Should a major hurricane strike the southern peninsula directly, hundreds of lives could be jeopardized and thousands of buildings could be totally destroyed. The realization of this fact led OXFAM to consider what could be done to protect people and property in the south of Haiti and what reconstruction strategies could be taken in the event of another hurricane.

In 1979, after Hurricanes David and Frederic struck the Dominican Republic, OXFAM and Catholic Relief Services (CRS) jointly sponsored a program to help low-income families rebuild their houses using indigenous materials and construction techniques. In that project, OXFAM retained INTERTECT, a Dallas-based firm specializing in housing reconstruction and disaster preparedness, to help identify low-cost methods that could be used to improve traditional buildings to better enable them to withstand future hurricanes. These methods were then taught to local tradesmen and homebuilders so that they could rebuild safely and economically.

Based on the experience in the Dominican Republic, OXFAM concluded that, if the same type of housing improvement activities could be carried out before a hurricane as part of the ongoing housing construction process, future losses could be greatly reduced. Thus in May 1982, OXFAM contracted INTERTECT to conduct a survey of housing in southern Haiti. The objectives of the study were:

- A. To identify and analyze the basic traditional housing types found in southern Haiti and construction techniques used.
- B. To determine design changes, improvements in the construction process, and improvements in the use of local building materials that can make the housing more wind resistant at a cost affordable to the rural poor.
- C. To recommend means of encouraging safer construction methods throughout the most vulnerable areas.

THE IMPORTANCE OF HOUSING IMPROVEMENT

This study has revealed a number of crucial shortcomings in the housing sector that go far beyond their implications for reducing vulnerability to hurricanes and point to the fact that any improvement in housing must be part of a comprehensive response to the overall problems of rural development in Haiti.

The most critical factor confronting the housing sector is lack of wood. The deforestation that threatens the agriculture and economy of the country is the cause of this shortage, and the reforestation efforts of the government and private agencies may inadvertently be causing further problems in the housing sector. The problem can be easily summarized. First, all of the basic housing types rely on timber for the structural frame and roof support. As deforestation has progressed, the wood available for construction has decreased and homebuilders have been forced to rely on smaller and shorter trees with the result that important structural members have had to be downsized (thus weakening the frame)

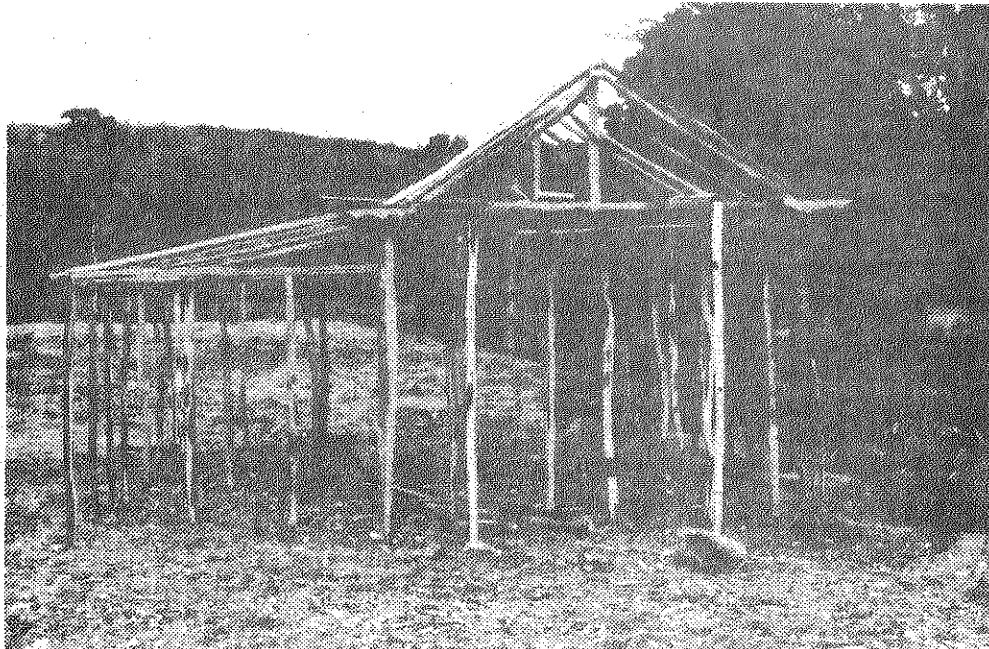

or made from gnarled, shorter pieces of wood. If straight timbers are not used, the walls will inevitably bulge or lean outward. Walls that are not vertical deteriorate rapidly; after only a few years they will begin to lean even more and eventually will pull away from the frame and collapse. There is already evidence that this is happening to a great extent. Signs such as collapsed and abandoned buildings, exposed foundations of buildings that have been replaced, as well as large numbers of recent buildings which are out of plumb

(i.e. with walls that are leaning), can be seen throughout the south.

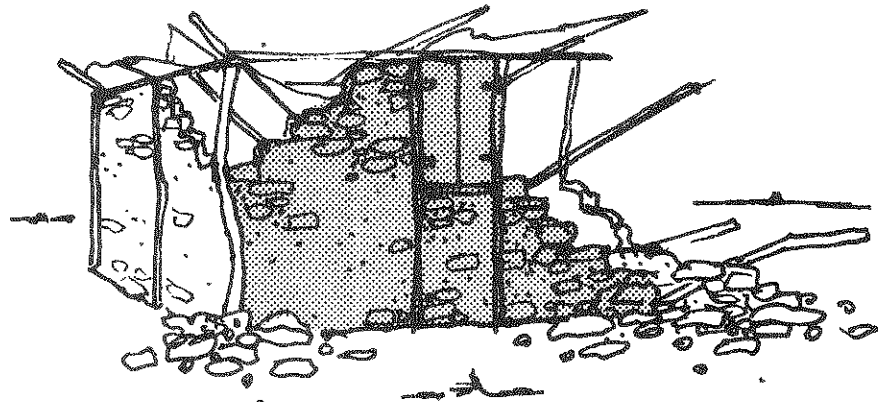
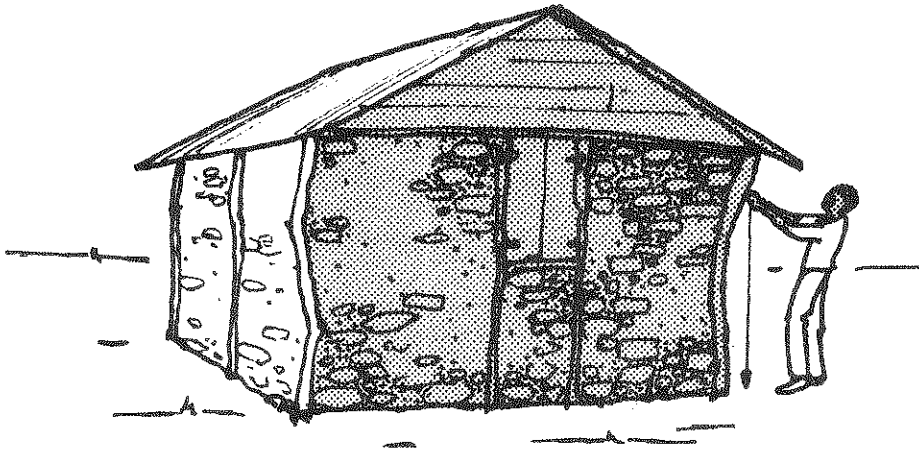

The implications of this widespread deterioration are two-fold. In terms of hurricanes, the number of people vulnerable to high winds is increasing dramatically. But more important, in terms of the economic impact on the poor, the rapid deterioration of housing represents an incredible burden and hardship. In the past, housing was expected to last 20 to 30 years; but with today's deterioration the average life of a structure is about 10 years and sometimes even less. This means houses must be replaced twice as often. With the cost of construction increasing annually (from an average of US\$150 10 years ago to approximately US\$400 at present), the average peasant family must devote an increasing amount of money to meet basic shelter requirements or continue to further marginalize the family's housing.

Unfortunately the reforestation efforts currently underway do not appear to be addressing the problem. Reforestation projects have concentrated on planting fast-growing species of wood that promote soil stability and provide good fuel sources. These types of trees, however, are generally soft woods and are unsuitable for construction purposes (soft woods deteriorate rapidly and do not resist insects such as termites). Nevertheless, some of this timber is now found in some of the newer houses in areas where reforestation programs have been carried out. Use of these woods will further increase the vulnerability of the houses and promote even more rapid deterioration.

In summary, without housing improvement activities and corresponding changes in reforestation policies:

- A. housing will continue to deteriorate;
- B. the number of people in vulnerable buildings will increase (and thus greater loss of life will occur in disasters);
- C. the housing replacement interval will decrease;
- D. the percentage of money dedicated to housing by peasant families will increase to a disproportionate level of the family's total annual expenditures.

On the other hand, if the government and/or private agencies commit even limited resources to a comprehensive program of housing improvement, the potential impact would be:

- A. to lessen vulnerability;
- B. to reduce maintenance costs of the houses;
- C. to prolong the life of the houses (and thereby increase the replacement interval), reducing replacement costs.

The principal housing types in Haiti can be improved at very little, and sometimes even at no, cost if the improvements are made when the houses are built. Many existing buildings can also be modified to increase their lifespan and to make them more wind resistant. The vast majority of existing buildings, however, cannot be economically retrofitted or modified at a cost anywhere near affordable to homeowners. This report identifies some of the measures that can be taken to improve housing and emergency measures that can be taken to increase the level of safety for persons living in buildings which are unlikely to survive windstorms.

It is recommended that the private agencies and the government undertake a concerted effort to improve the quality of new construction and to disseminate information throughout high risk areas on how to increase the level of safety in small buildings when a hurricane threatens. The measures that are recommended are not expensive or complicated, but their introduction and promotion until they become a part of routine construction practice will require a long-term commitment by concerned development agencies.

II. RISK AND VULNERABILITY IN HAITI

HURRICANE RISK

Haiti is situated in one of the most active hurricane regions in the world. Within the last 30 years, eight hurricanes and numerous tropical storms have struck the country.*

Hurricanes threaten housing in four ways:

- Damage or collapse resulting from the forces of high winds;
- Inundation from storm surges (popularly known as tidal waves) affecting lowlying coastal areas;
- Inundation from flooding caused by the high rainfall accompanying the storm; and
- Damage resulting from landslides, mudslides or other displacements caused by supersaturation of the soil by heavy rainfall.

All of these hazards exist in southern Haiti and many communities are threatened by two or more of these hazards.

Figure 2 depicts the tracks of hurricanes which have struck Haiti in the last 30 years. Figure 3 depicts a cross-section of a typical hurricane, showing the sector of the storm system that produces the most damage. It can be seen from this drawing that the band of destruction can be fairly wide, often spanning a diameter of up to 100 miles. Thus, a large storm could do considerable damage to a wide area of the country.

High winds can cause extensive damage in any type of structure but generally lightweight buildings, especially those made of traditional materials, are more susceptible to damage if basic hurricane resistant building features are not incorporated into the design and construction. Through experience, traditional buildings are often modified by local building craftsmen to enable the buildings to better withstand high winds. There is evidence that several features such as four-sided hipped roofs and certain structural building techniques have been developed to strengthen the structures in this

* l'Espace Haïtien, Georges Anglade, Editions des Alizés, Montreal, 1981.

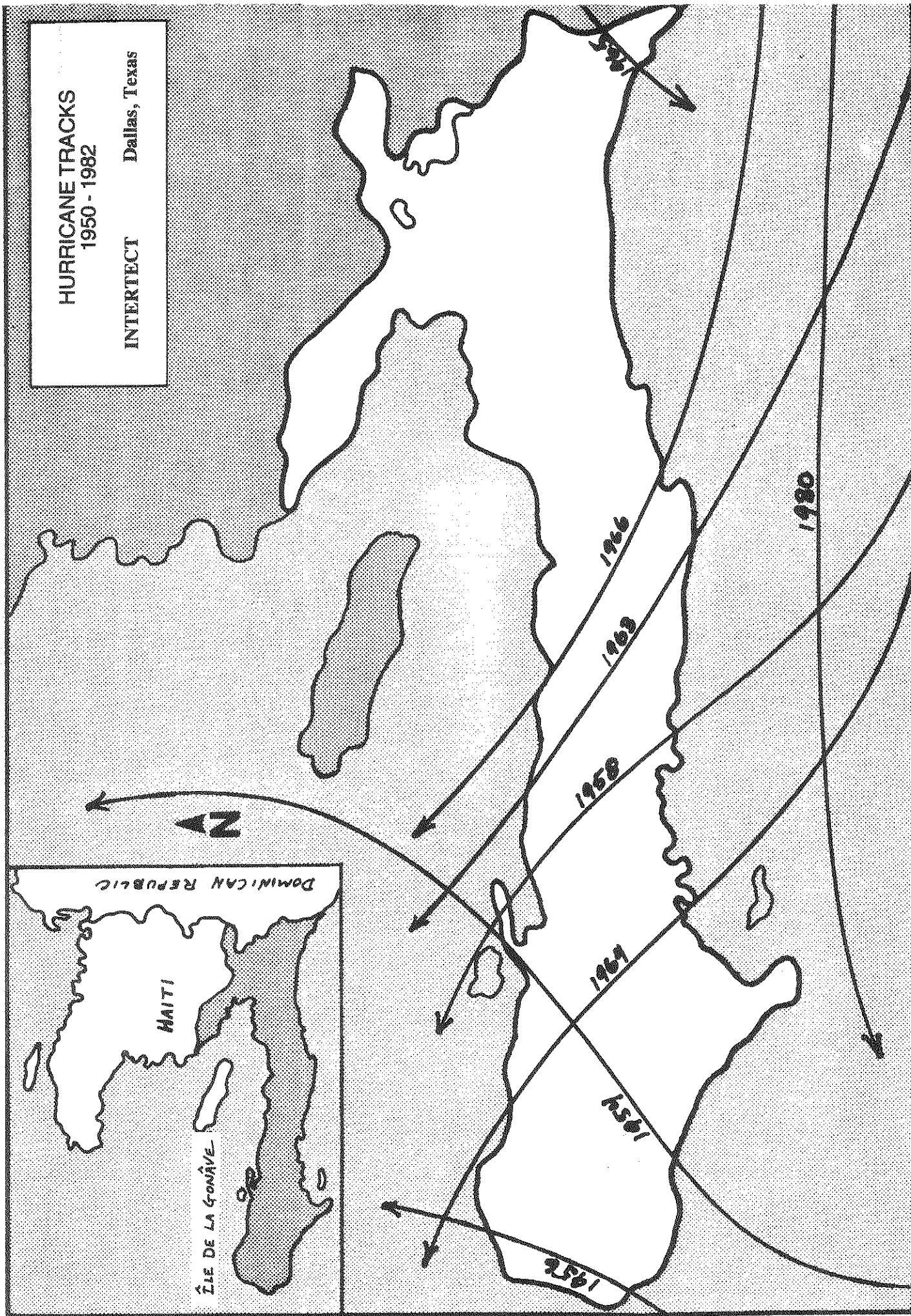

FIGURE 2

A HURRICANE STORM SYSTEM

INTERTECT Dallas, Texas

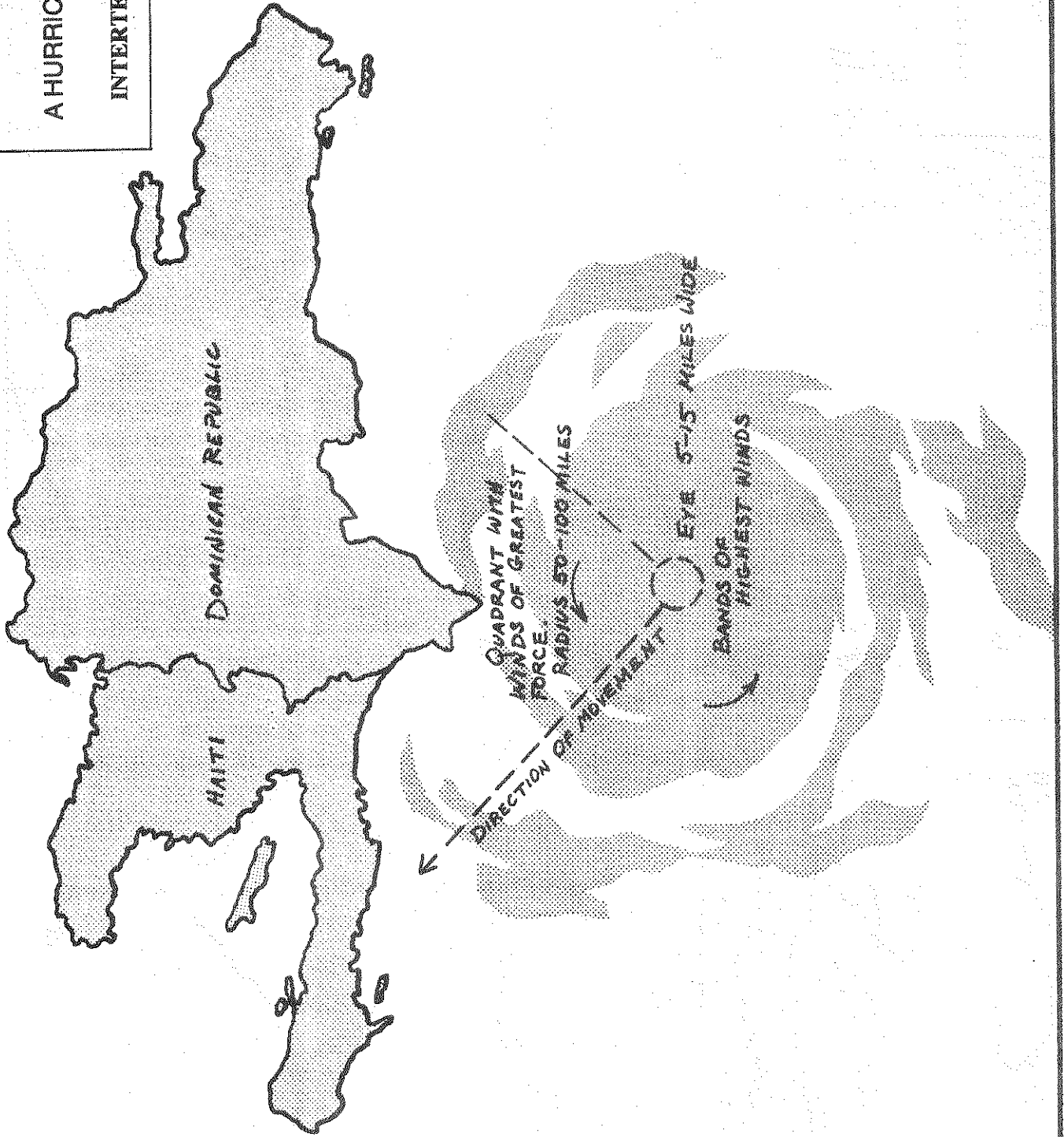

FIGURE 3

regard. However, as good grade construction materials have become more scarce, further modifications must be made in order to strengthen the buildings. Because few houses are built with engineering advice, the majority of buildings do not have adequate resistance to high winds.

Mountain valleys that open directly onto the sea coast catch and compress the winds blowing into the valley. This "funnel effect" speeds the wind and causes much higher wind pressures than would be felt in other areas. Thus, houses or communities built in mountain valleys that run perpendicular to the coast require extra precautions and structures must be especially sound in order to reduce damage.

Figure 4

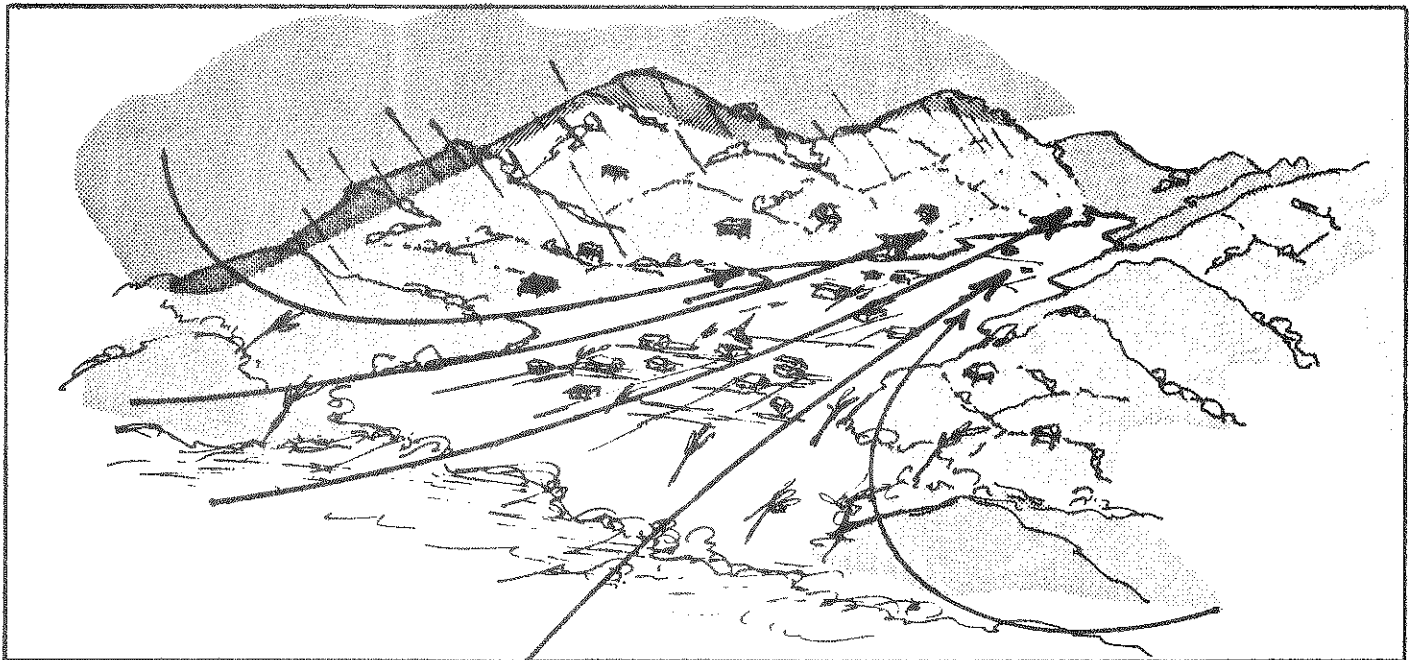

Figure 5 shows those areas where extensive deforestation has occurred. These areas are especially susceptible to landslides and flooding. As mentioned in Chapter 1, deforestation has also contributed to increased structural weaknesses in the local housing. Therefore, it should be clear that reforestation is a key to vulnerability reduction in more ways than one.

A storm surge (popularly known as a tidal wave) is a rapid rise in the water level that often comes ashore in the form of a large "mound" of water with accompanying destructive waves. These surges, which can rise to a level of 20-30 feet, threaten coastal communities

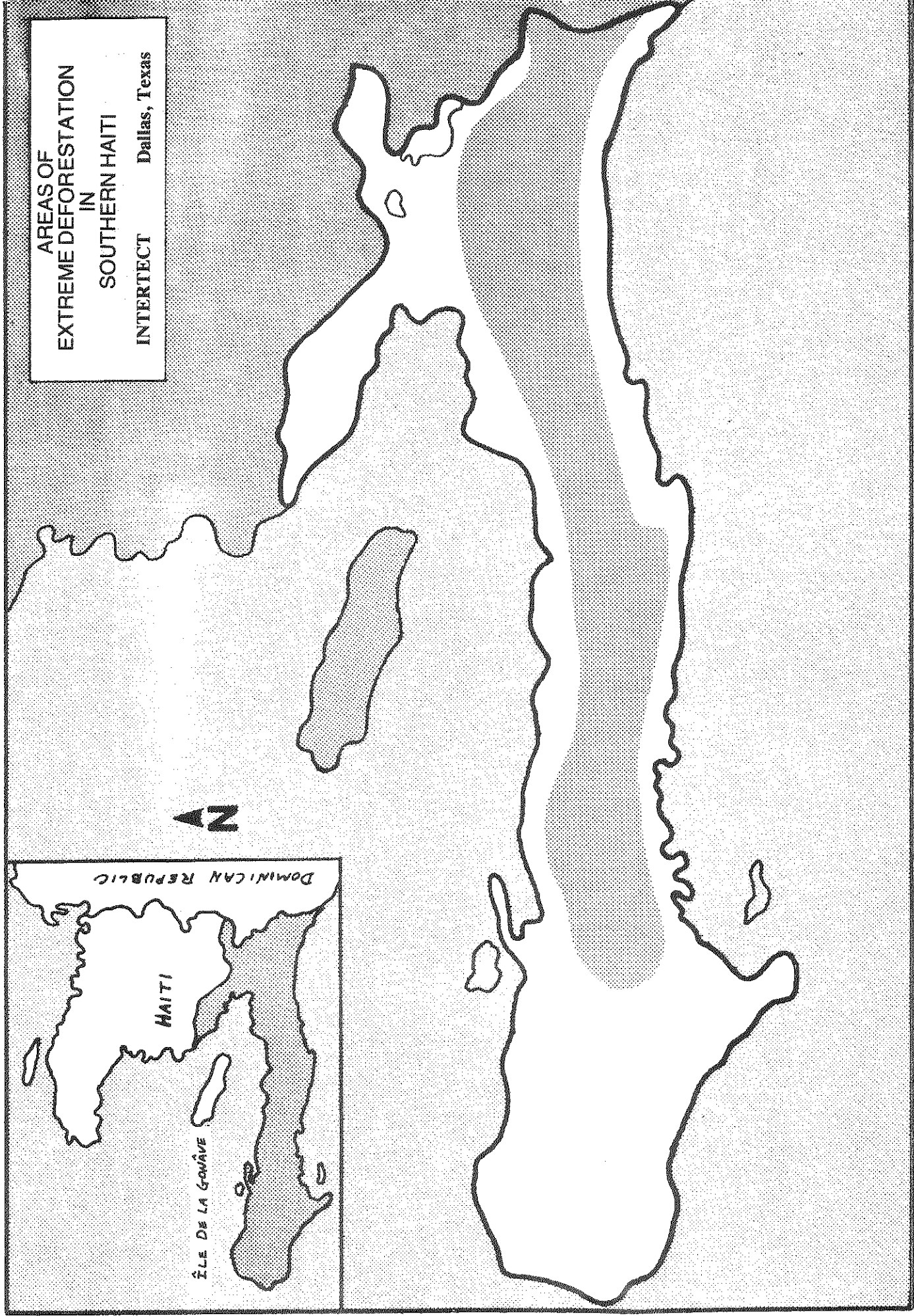
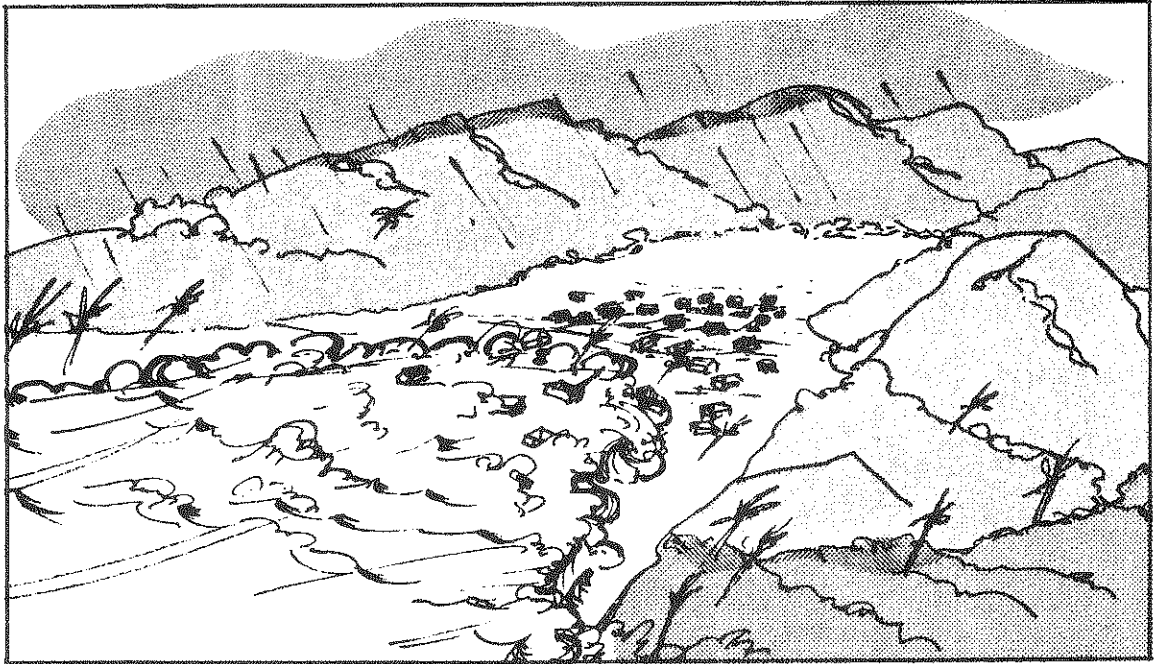

FIGURE 5

especially those in crescent-shaped bays where a direct strike from a hurricane might occur.

Figure 6



Nothing can be done to modify a house to protect it from a storm surge, as wave action as well as the flooding will totally destroy almost any type of structure in its path. Therefore in those communities that are threatened, the best action to take is to evacuate the communities to a level above the estimated height of the storm surge. This is not to say, however, that houses in these communities should not be strengthened to resist high winds, for the likelihood of hurricane-force winds striking a community is probably far greater than the likelihood of a storm surge striking any one particular community. The following is a list of communities that may be susceptible to storm surges and for which evacuation plans should be developed:

- | | |
|------------------------|---------------|
| --- Marigot | --- Baintet |
| --- Côtes-De-Fer | --- Aquin |
| --- Saint-Louis-Du-Sud | --- Les Cayes |

EARTHQUAKE RISK

Assessment of earthquake risk and vulnerability was not a part of this study; however, damaging earthquakes have occurred in Haiti. Although most have been in the north, some degree of risk does exist for the south, and a major earthquake occurring in the north with sufficient magnitude could cause extensive damage in many southern zones. The types of buildings most susceptible to earthquake damage are heavy, low-quality masonry buildings --- exactly the types found in the south.

Fortunately, many of the measures that can be taken to reduce vulnerability to strong winds also reduce vulnerability to earthquakes. Often specific measures to reduce earthquake vulnerability can be incorporated at the same time as measures to reduce high wind vulnerability, with little or no additional cost. Thus it is important that the threat be recognized and that appropriate measures be taken at the same time that houses are strengthened to resist hurricanes.

FIRE HAZARDS

Another major hazard that should be mentioned is fire. Fires in overcrowded urban areas, where houses made of makeshift materials are built immediately adjacent to each other, can quickly engulf large areas. A recent fire in Port-au-Prince left thousands homeless. Squatter settlements are especially dangerous because houses have inadequate cooking facilities and little or no electric lighting. If a fire breaks out, it is difficult to control because the settlements usually have inadequate water supplies. The best course for agencies working in these communities to reduce the hazard is to design or redesign the communities with sufficient space left between the buildings to provide firebreaks. The homes themselves should be made of stone, concrete block or other non-flammable materials and should have metal or fiber-cement roofs.

ESTABLISHING PRIORITY AREAS FOR VULNERABILITY REDUCTION

As a general rule, comprehensive vulnerability reduction efforts should be initiated in areas where there are certain indicators that such efforts will succeed. Among the indicators are: areas where new construction is occurring (such as the growth areas around cities and towns); areas where agricultural activities are strong and where migration from rural to urban areas is minimal; and areas where a threat from a disaster is perceived as a major problem to the majority of homeowners within the region. By examining demographic trends

and density in regions of economic growth, priority areas for establishing vulnerability reduction efforts can usually be identified.

There are no such clear-cut indicators in south Haiti. Due to the widespread nature of the hazards and the extreme poverty and deforestation, as well as the terrain and relatively narrow width of the peninsula, priorities for vulnerability reduction must be set on the basis of operational considerations --- in other words, where the development agencies have strong integrated rural development, reforestation and/or appropriate technology programs. In general, coastal settlements on the south coast should receive a higher priority than communities on the north coast of the peninsula due to their exposure to a direct hit from hurricanes. Whichever area is selected, a major objective should be to quickly expand activities throughout the region.

III. GENERAL DESCRIPTION OF HOUSING TYPES

BASIC HOUSING TYPES

In Haiti traditional housing types (called "kays") can be classified according to the type of material and building system used to make the walls. There are six distinct types of houses found in Haiti:

A. Kay Ajoupa (Wattle or Reed Houses): These houses are made of a wood pole frame with cane or sticks woven between the vertical posts. These are the houses of the very poorest of the rural Haitians.

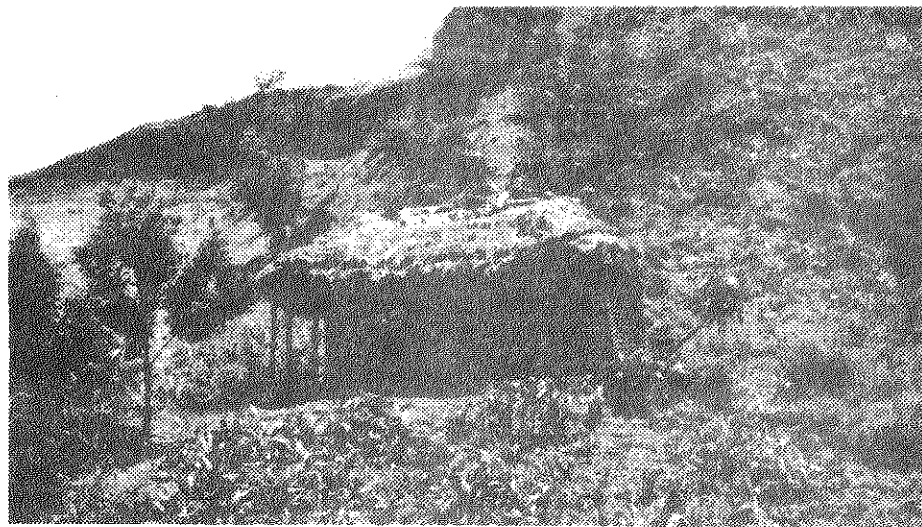

B. Kay Klisé (Wattle-and-Daub House): These houses are identical to those made of ajoupa except that the walls are covered with a mud stucco. The stucco waterproofs and helps to strengthen the house. Generally, the kay klisé is more permanent and the building system, when done well, can last many years.



- C. Kay Mur (Stone Nog): These houses are made by cementing small stones between a wooden frame. This is the most popular type of housing found in the southern peninsula.

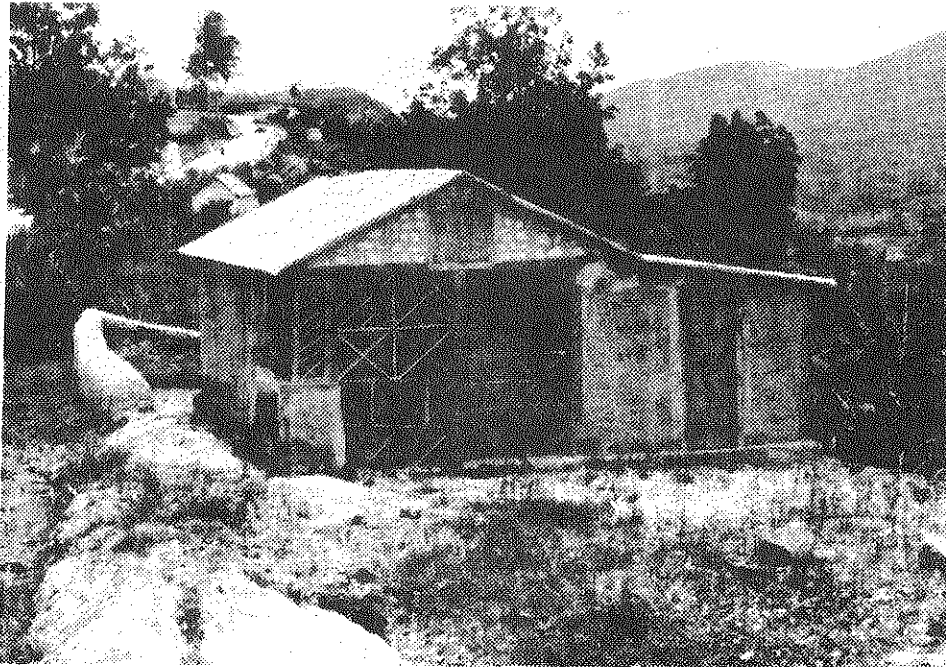

- D. Kay Mélange (Spanish Wall): These houses are similar to the kay mur type of construction in appearance and form but the construction process is slightly different. Stones are also cemented between a wooden frame but the stones are smaller and a board attached to the inside of the wall is used as a guide for the stone masonry.



- E. Kay an Planch (Wood House): Wooden houses are made of locally available timber or wood salvaged from urban construction sites. Because deforestation has made wood so scarce, few new houses are made now and palm wood, once very rarely used in housing, can be found in some areas.

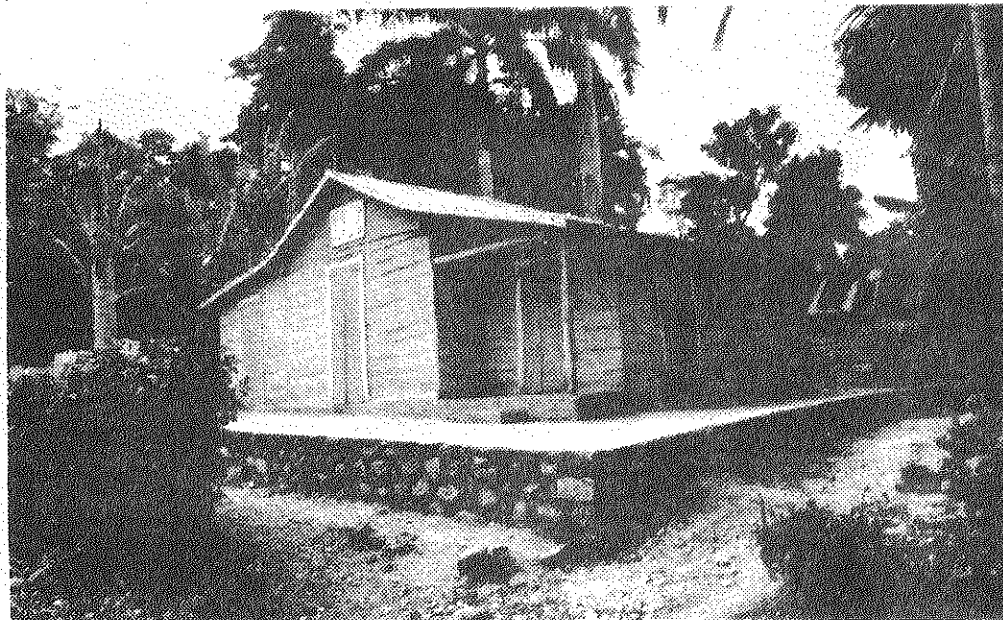

- F. Kay an Blòc (Block House): These houses are made of cement block.

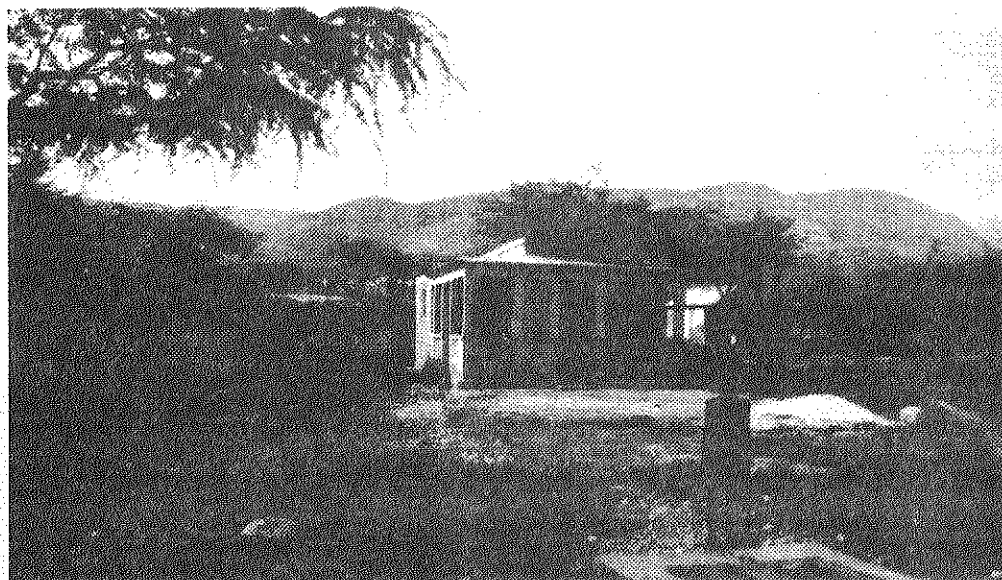

All of these housing types are found throughout the region in virtually every community with little change in construction technique.

POPULAR DESIGNS

An interesting feature of housing in south Haiti is that in each community certain designs and styles predominate, even though the building materials chosen may be different. Buildings may be identical in form and shape right down to the detailing of doors and windows. This undoubtedly is due to the predominance of a certain builder and illustrates the importance of local building tradesmen in the housing sector. (This will be discussed in more detail later in the report.)

The most popular designs are shown below. Communities where distinctive architecture can be found are shown on the map in Figure 7.

A.

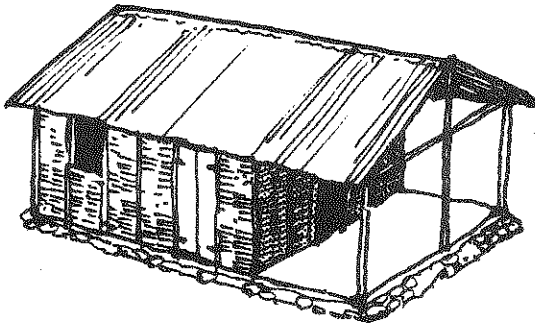

Construction: Ajoupa
Klisé
Mur

Comments: Extremely vulner-
able to high wind

B.

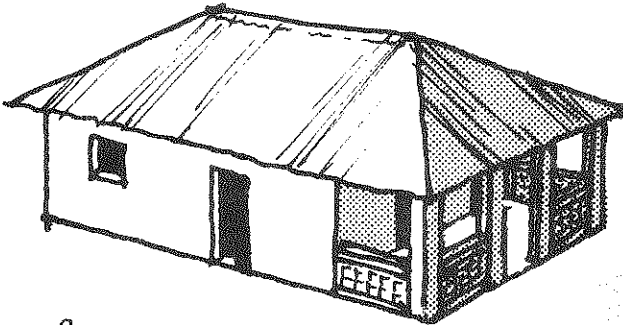

Construction: Klisé
Mur
Mélange

Comments: Fairly vulnerable
because winds can
push upward on
roof under veran-
da.

C.

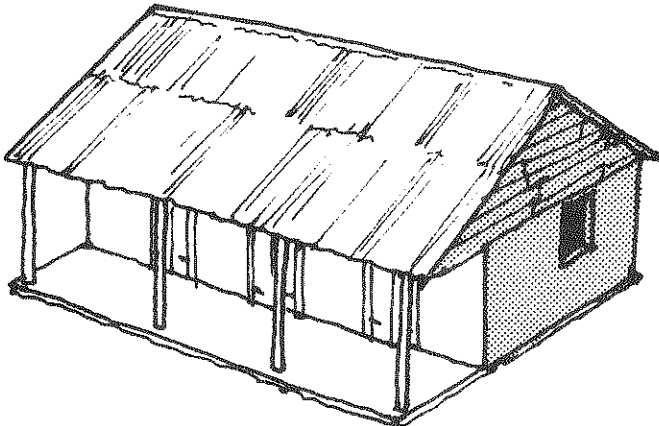

Construction: Klisé
Mur
Mélange

Comments: Fairly vulnerable
because winds can
push upward on
roof under veran-
da.

D.

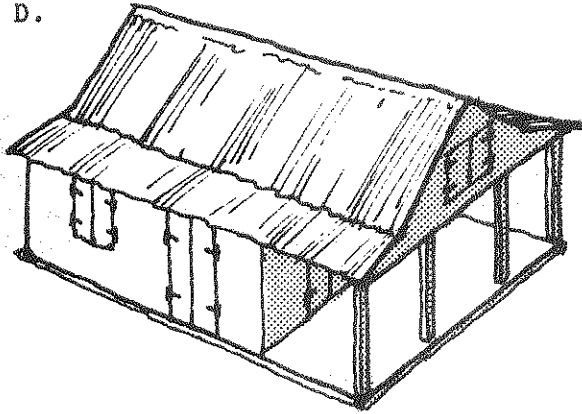

Construction: Mur
Mélange

Comments: Multiple roof lines help reduce vulnerability but veranda increases risk of roof damage.

E.

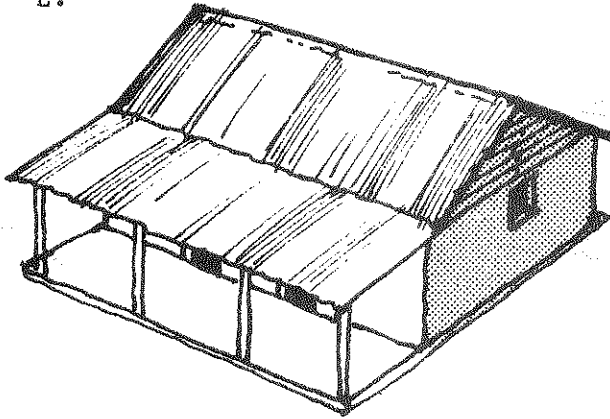

Construction: Klisé
Mur
Mélange

Comments: Fairly safe; damage to veranda will not harm roof.

F.

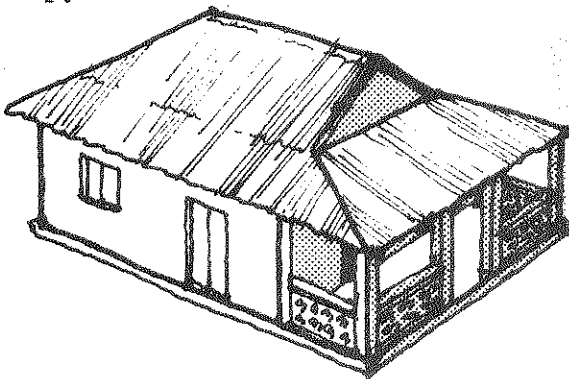

Construction: Mur
Mélange

Comments: Strong basic design; veranda unlikely to damage roof if blown off.

G.

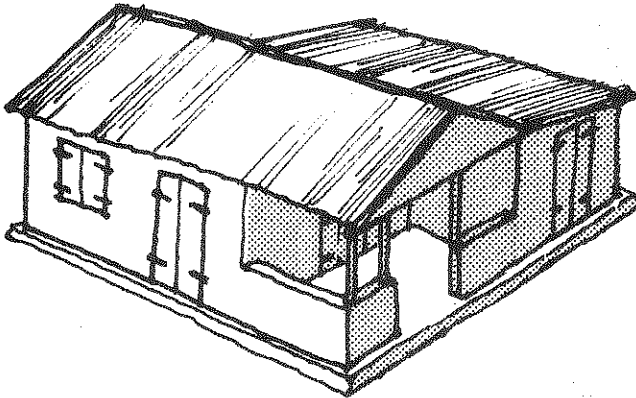

Construction: Mur
Mélange
Planch

Comments: Strong basic design, although damage to roof can be expected if veranda blows off.

H.

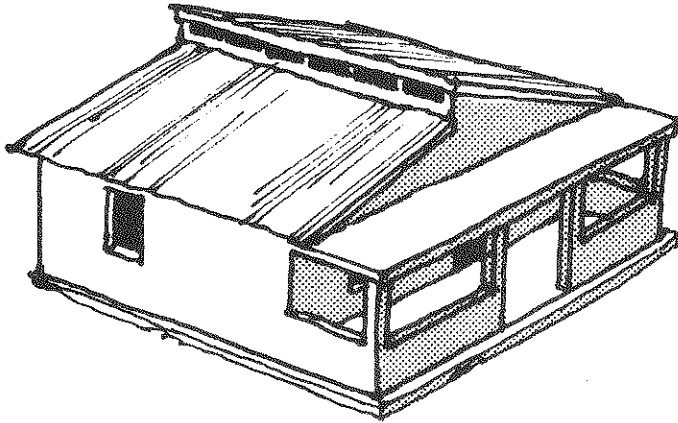

Construction: Blde

Comments: Strong design; damage unlikely if well built.

ROOFS

The most favored roofing material is corrugated iron sheeting laminated with zinc. Many houses have roofs made of thatch, usually palm leaves, although some use grass or reeds. Each of these types of roof can be found on any of the basic building types and on all of the various popular designs.

DISTINCTIVE HOUSING PATTERNS
IN
SOUTHERN HAITI
INTERTECT Dallas, Texas

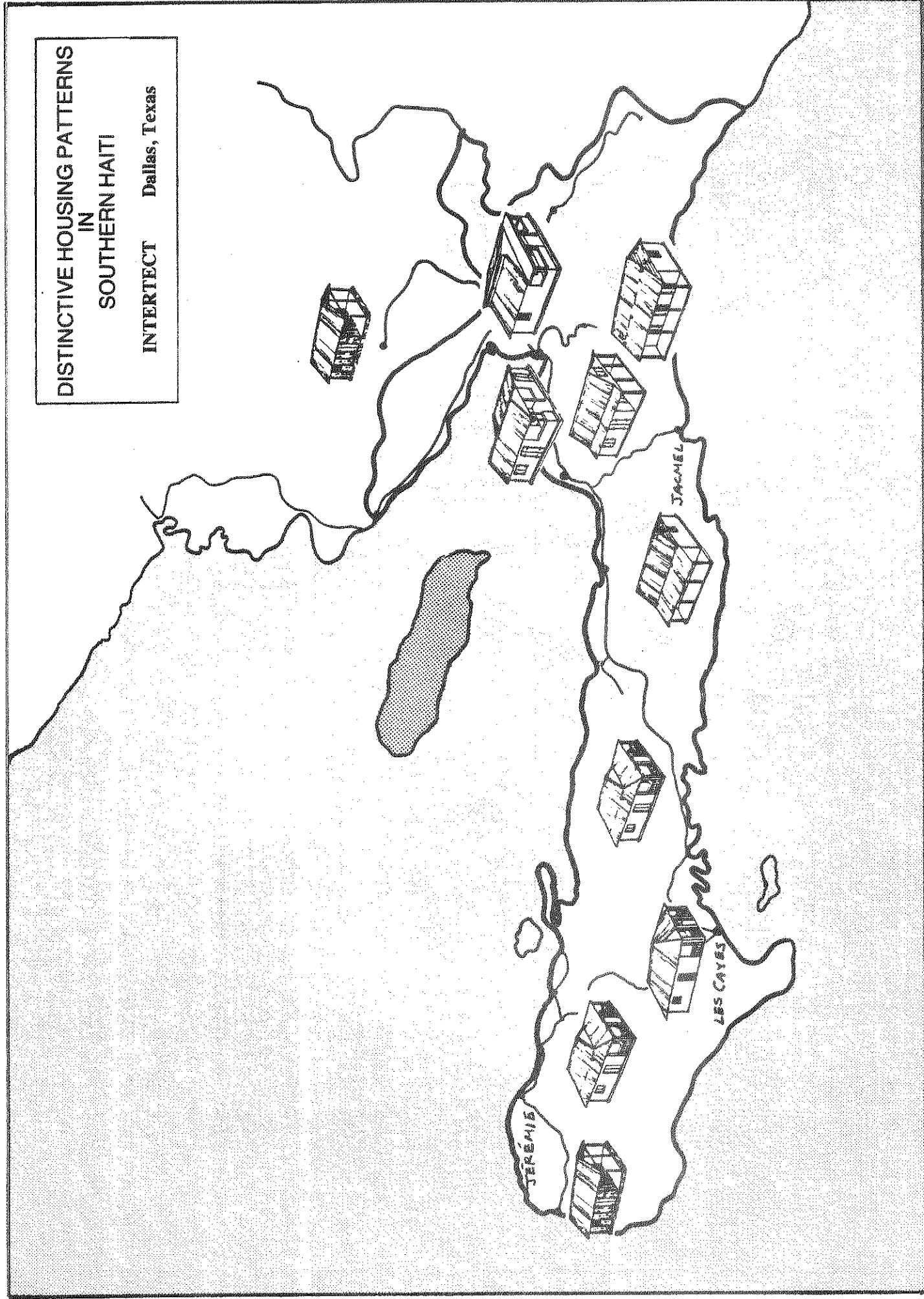

FIGURE 7

IV. VULNERABILITY ANALYSIS OF TRADITIONAL HOUSES IN HAITI

The purposes of this chapter are to identify the structural problems of each housing type, to determine their relative vulnerability to high winds, and to explain options for improving the structural performance of each building type.

WHAT MAKES HOUSES SAFE IN HURRICANES?

Contrary to popular belief, few houses blow over in a hurricane. Most buildings actually "explode" outward. This happens for two reasons. First, the wind rushing over the roof and around the house lowers the pressure on the outside of the house. The pressure inside the house remains constant but, because the outside pressure is less, the air inside expands, pushing the walls and roof outward. Second, the air flowing over the roof creates a suction, similar to the lifting action on an airplane wing, that pulls the roof upward. (Some suction also pulls on the walls that are parallel to the wind if they are smooth.) This is why roofs receive so much damage in windstorms and why it is important that a house be tied together well.

The factors that determine how vulnerable a house is to high winds are: the design and configuration of the house; the quality of workmanship; the strength of the materials used; and the relative safety of the site. In general, buildings made of lightweight materials are more susceptible to damage from high winds, while buildings made of heavier materials, such as block or stone masonry, are less vulnerable.

Specifically, vulnerability is a function of:

- the configuration of the building (buildings should be as square as possible);
- the configuration of the roof (a four-sided or "hipped" roof is best);
- the angle of the roof (a 30°-45° angle is best);
- how well the building is tied or nailed together;
- how securely the roof is fastened to the walls; and
- how well the building is anchored to the ground.

Lightweight structures with wood frames, especially older buildings where wood has deteriorated and weakened the walls, are very vulnerable but their failure is not likely to seriously injure the occupants. Houses made of unreinforced or poorly constructed stone masonry or concrete blocks are also vulnerable to damage and are more likely to cause injury if they collapse.

Roof configuration and construction are very important considerations for all types of housing. Roofs receive more wind pressure and force than any other part of the house. If the roof is not adequately attached and braced, and has a large overhanging eave, it will be blown off the walls and potentially cause damage to other parts of the house.

Vulnerability of housing to earthquakes is determined by many of these same factors, plus several others. In addition to configuration and structural integrity, other determinants are:

- the site (it should be flat with stable soils)
- the foundation (it should be strong and level)
- balance (parallel walls should be of equal size and weight)
- height of the walls (they should be low)
- weight of the roof (it should be as light as possible)
- the amount of reinforcement in the walls (adequate vertical, horizontal and diagonal reinforcing rods or braces should be placed in each wall).

POPULAR BUILDING FEATURES

A. Building Features and Practices That Reduce Vulnerability

1. Hipped Roofs: Most buildings in the south use "hipped" roofs. These offer excellent protection in high winds and continued use of this roof configuration should be encouraged.

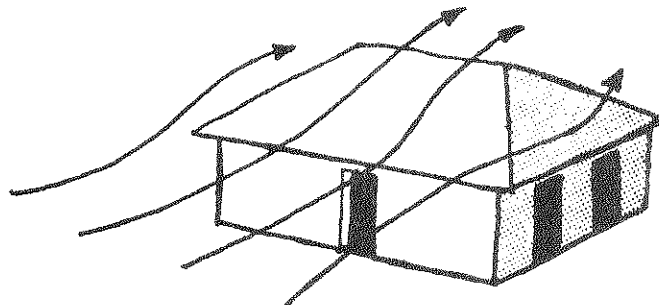

2. Hurricane Straps: In many older buildings, the practice of tying roof rafters to the wall frame was common. This was the best way to hold the roof down in high winds and planners should encourage people to continue this practice rather than nailing the roof frame to the wall. Wire or metal strips can be used and add great strength.

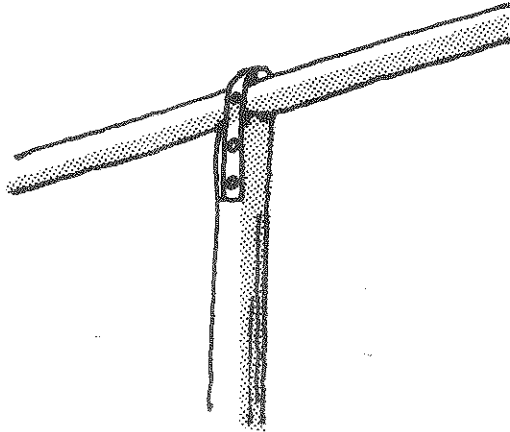

3. Small Eaves: The roofs of most traditional buildings project only a few inches over the sides of the walls. This reduces uplift under the eaves and prevents damage to the roof.
4. Strong Building Sizes & Shapes: Most buildings in the rural areas are an excellent shape and size to withstand high winds. Only in the towns and cities are houses built in a long and narrow manner that would make them unstable.

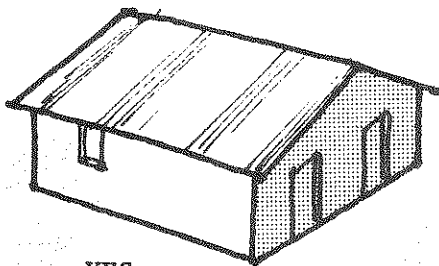

YES

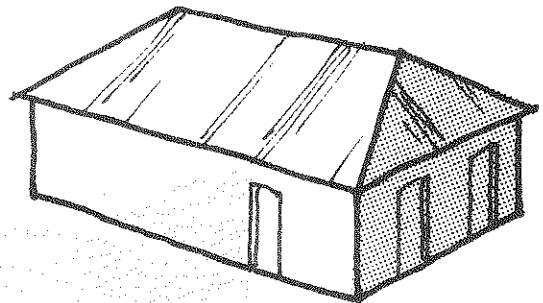

YES

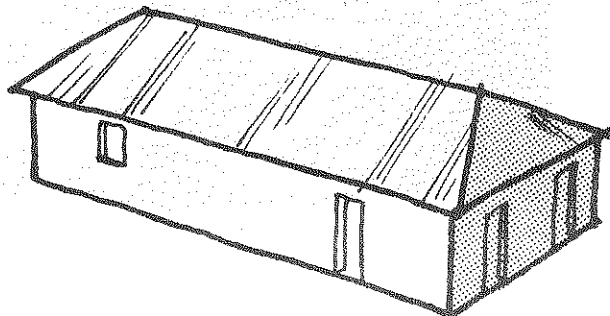

NO

5. Multiple Roof Lines: A roof with many different sides and angles makes it difficult for the wind to lift it off. Several popular designs have roof styles that help reduce wind damage.

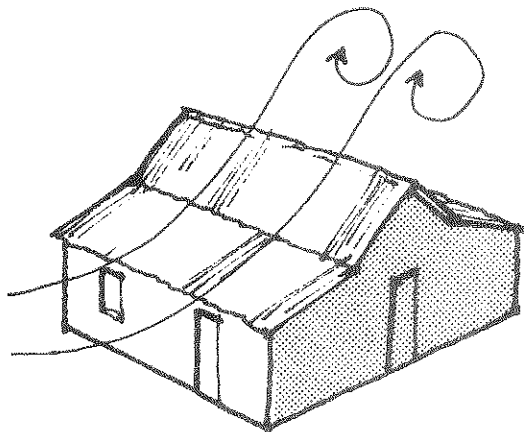

6. Rough Walls: Walls with rough, uneven surfaces such as un-stuccoed stone walls generally make it more difficult for wind to flow around a structure and break up the suction on the walls. Most stone masonry and wattle-and-daub buildings fit this description.
7. Siting: The siting of a house in a community can have an effect on the flow of wind. Houses that are not in straight lines or in a regular pattern can shield each other and break up the wind gusts. The irregular nature of many rural villages actually helps reduce vulnerability.



8. Windbreaks: Natural features such as stands of trees or shrubs, outcroppings of rock, and man-made features such as stone walls, mounds, etc., can help to shield houses from winds as well as flying debris. In some cases windbreaks can be designed to deflect winds over or around buildings. In reforestation programs, windbreaks should be planned.

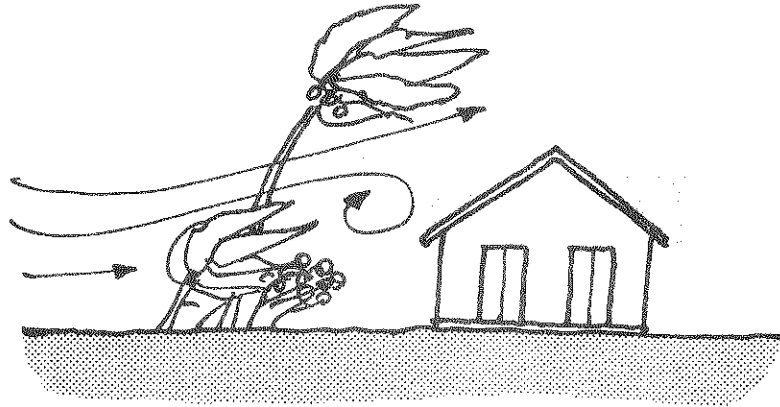

9. Foundations: By placing the walls directly on the ground (on foundations instead of posts or stilts), air is prevented from flowing under the structure and blowing it over. Only a few wooden houses are put on stilts or piers; the remainder are built in the best way to resist high winds.

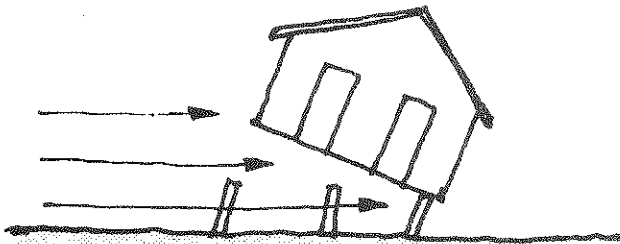

NO



YES

10. Low Walls: Houses that are built with low walls will resist winds (and earthquakes) better than houses with high walls and heavy roofs. This is because winds close to the ground are not as strong as those higher on the wall and because low walls are generally stronger and easier to reinforce than tall ones. The walls of most Haitian houses are the correct height for wind resistance.

B. Features and Practices Increasing Vulnerability

1. Low Pitched Roofs: In recent years low pitched or "shed" roofs have become popular, especially in houses built by development agencies. This configuration is especially vulnerable to damage in hurricanes. The low pitch increases suction and uplifting forces.

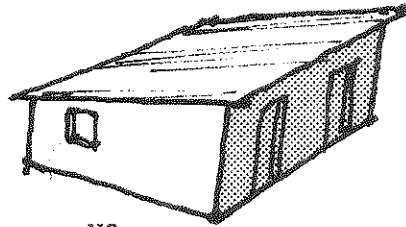

NO

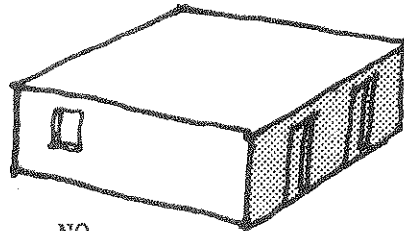

NO

2. Louvered Windows: Louvered windows have become popular in houses of upwardly mobile low-income families, and louvers are often installed in houses built by agencies. Louvers, particularly those made of glass or flimsy metal, can be dangerous in hurricanes. Vibrations caused by high winds can cause metal fatigue, destroying the louvers and permitting excessive amounts of wind to enter the house. Glass louvers can be shattered by flying debris, injuring persons inside the house. If louvers are used, storm shutters should be added.

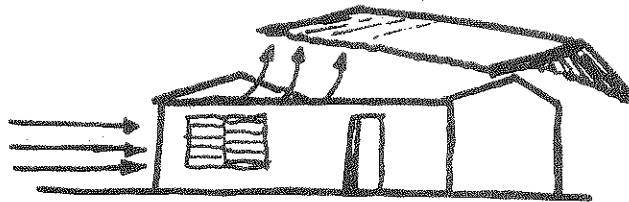

3. Verandas: Verandas, or open porches, are a popular feature on many houses. Many of the designs used in Haiti contribute to wind damage because the veranda is formed by extending the roof out over the entrance to the house. Wind can be trapped under the veranda and may lift the whole roof

off the house. Verandas should be built so that only the part over the entrance will blow off without damaging the rest of the roof.

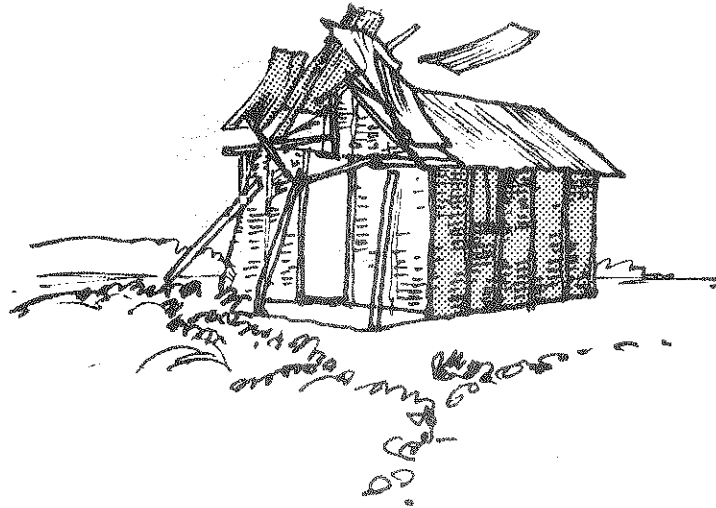

4. Stone Gables: In the central highlands near La Vallée, many houses are built with stone gables as shown below. These are difficult to reinforce. Hurricane winds can blow the gables into the house, injuring the occupants and letting air under the roof, lifting it off.

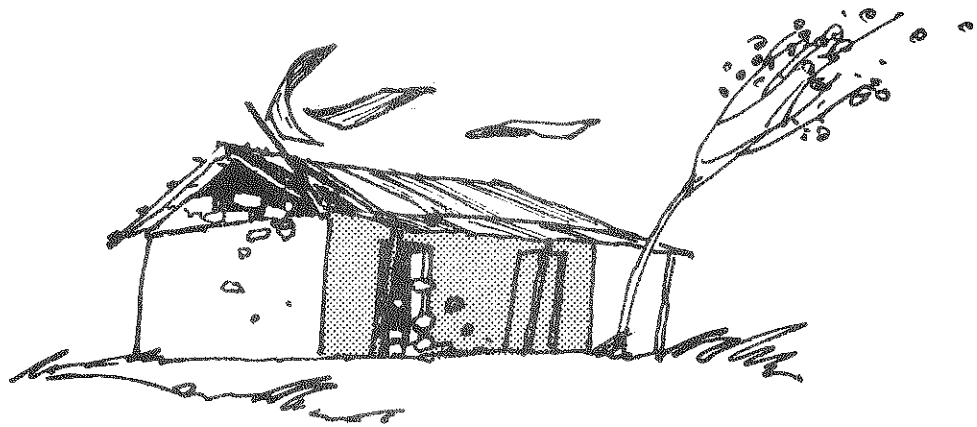

5. Corner Windows and Doors: In many areas, doors and windows are placed in the front corners of the buildings. This weakens the corners and may be the cause of major damage to

the building. Doors and windows should be a minimum of one meter from the corners.

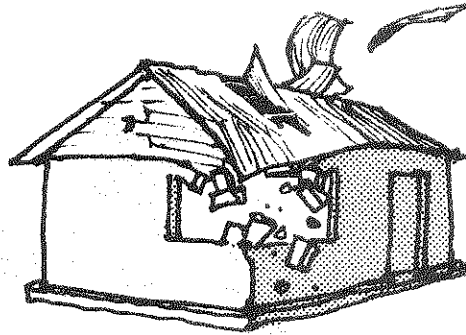

6. Proper anchorage: Many of the Haitian building systems use a wood frame for structural strength. Unfortunately the columns are not buried deep enough nor anchored in the ground; thus the buildings may be lifted out of the ground.

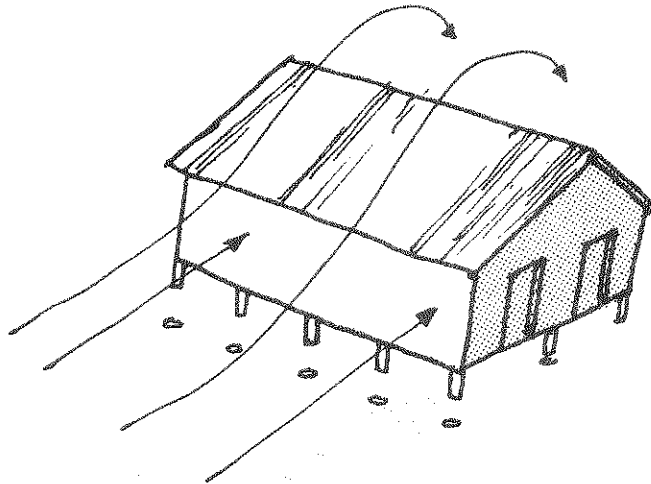

Proper anchoring devices, such as those shown below, should be used:

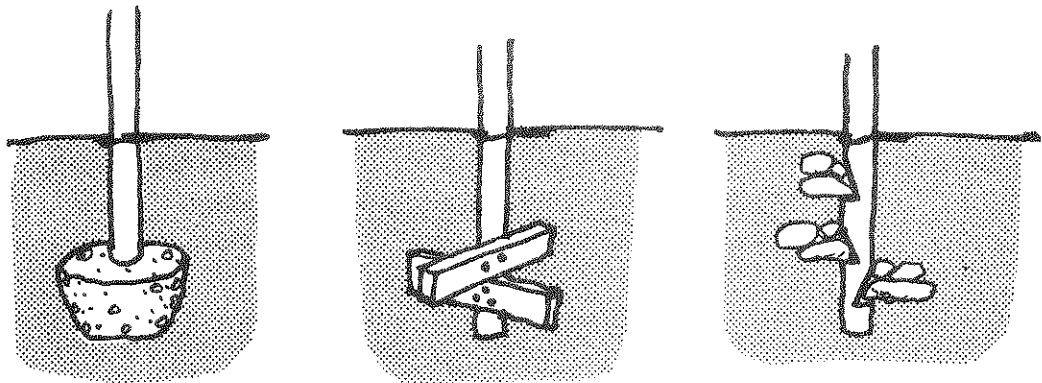

7. Deteriorating Wood: Many of the wood columns used in the buildings are greatly deteriorated due to rot or insects. Low-cost wood preservation methods must be introduced to help prolong the life of the various wood components. Two very low-cost methods that could be employed are soaking the wood in a mixture of crankcase oil and agricultural pesticide or charring the outside of the wood (charring forms a carbon barrier that insects cannot digest or penetrate).
8. Siting: In many new communities, houses are laid out in straight grids. This increases the wind speeds between the houses.

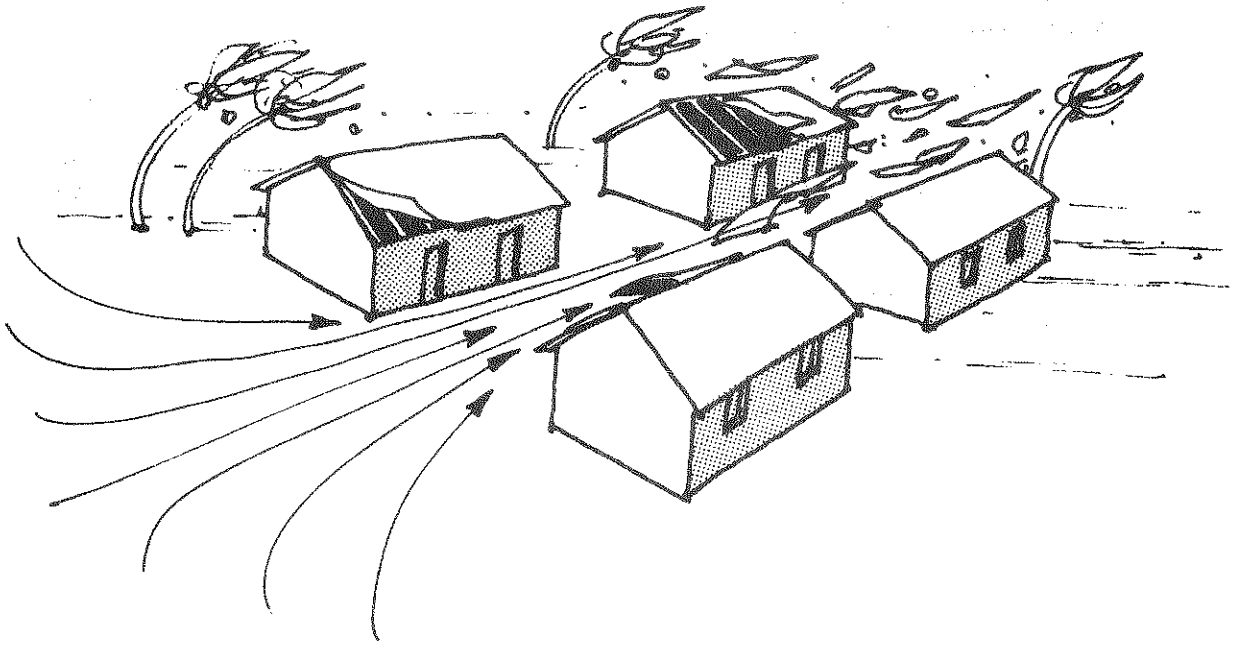

C. Summary

By comparing the two above sets of factors that either increase or decrease vulnerability, it can be seen that, if properly made, most Haitian houses would be fairly wind resistant. The basic building designs are not dangerous and the construction methods used are basically sound. Thus from the standpoint of housing improvement, there is far more to work with than is usually found in countries with similar hurricane hazards.

The deficiencies that do exist are due to a lack of construction skills, poor quality tools and a growing problem of inadequate building resources, especially good quality timber. The problems of

skills and tools are fairly easy to deal with. Construction training programs can be initiated to teach better building techniques, as well as how to make and maintain basic construction tools. On the other hand, the problem of developing building material resources and making materials available at a cost affordable to the rural poor will require major policy decisions and coordinated, comprehensive efforts among many development agencies.

VULNERABILITY ANALYSIS OF THE BASIC CONSTRUCTION TYPES

The following is an analysis of the principal housing types found in southern Haiti. Primary emphasis is on the wind resistance potential of each structure, as hurricanes and wind storms are the greater hazard due to their frequency. However, the earthquake resistance potential is also discussed briefly.

Most recommendations for making houses more disaster resistant can be incorporated at little or no increase to the total cost of new construction, but some modifications to existing building types are both expensive and technically difficult. Thus, recommendations are divided into two categories: simple low-cost changes which could be carried out to protect existing buildings when a storm threatens, and more sophisticated actions that could be carried out when new structures are built.

A. Ajoupa (Wattle or Reed Construction) and Klisé

Wattle-and-daub construction is one of the early forms of building and dates back to the earliest settlements, having been used by both French and Spanish colonists. Some historians believe that the method is reminiscent of African building methods, but the form and features of Haitian wattle-and-daub today clearly follow French lines and methods.

1. Construction: In ajoupa construction, a wooden frame is erected and bamboo, sticks or cane are woven between the vertical columns. Klisé houses use the same system but then cover the wall with mud to seal it. Usually a plaster is applied to both sides of the walls. The plaster is a mixture of mud and lime, usually with an application of lime wash over the outside.

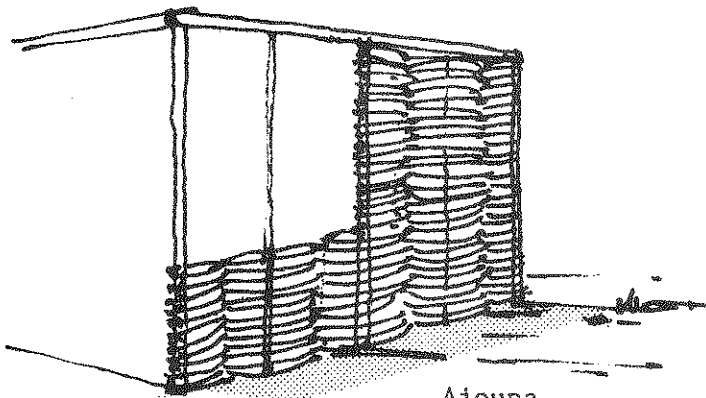

Ajoupa

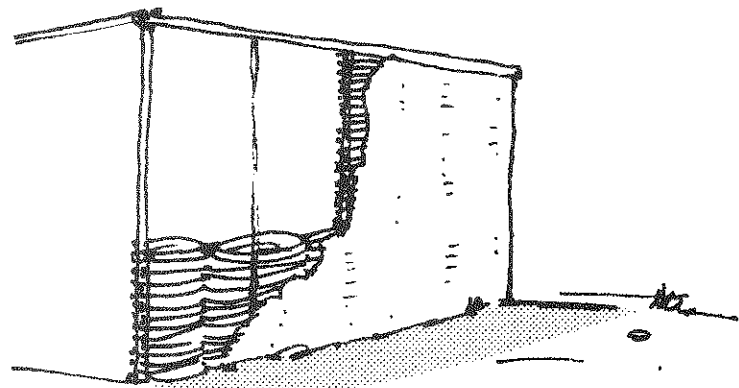

Klisé

2. Roof: Structures of this type normally have thatch roofs, although in recent years a larger number have been built with or converted to corrugated iron roofs.
3. Size: Houses built of wattle-and-daub are moderately sized, averaging about 4 x 6 meters.
4. Vulnerability: The older wattle-and-daub houses are very vulnerable to hurricanes because of deterioration of their wood frames. If damaged, the houses will be beyond repair and residents will be forced to rebuild an entirely new structure. The primary causes of structural failure are separation of the roof from the walls (caused by uplift on the roof's surface as well as uplift under the eaves of the roof) and collapse of the walls resulting from lack of reinforcement at the corners and lack of strength in the columns due to deterioration of the wood in the ground.

5. Other Weak Points: The weak points of the house are the wood columns, corners (which have inadequate diagonal reinforcement), and connections between the roof and the walls.

6. Modifications for Wind Resistance: In order to improve the wind resistance of wattle-and-daub houses, the following actions are recommended:

a. Emergency measures

- Increase the number of nails used to fasten iron sheets to the roof frame.
- Place wood braces in the roof framing.
- Strengthen the roof-wall connection by using metal straps or wire to help bind the roof to the wall, especially at the columns.
- Board up the windows when a hurricane approaches.
- Place heavy objects such as bricks on the roof to break up suction created by the wind.

b. Measures for new construction

- Use wood treatment for all parts of the house that are placed on or in the ground.
- The primary columns (those in the corners and in the middle of each wall) should be buried a minimum of 24 inches and should use some form of anchoring device.
- Cross-braces of galvanized wire should be placed between all the primary columns of the building.

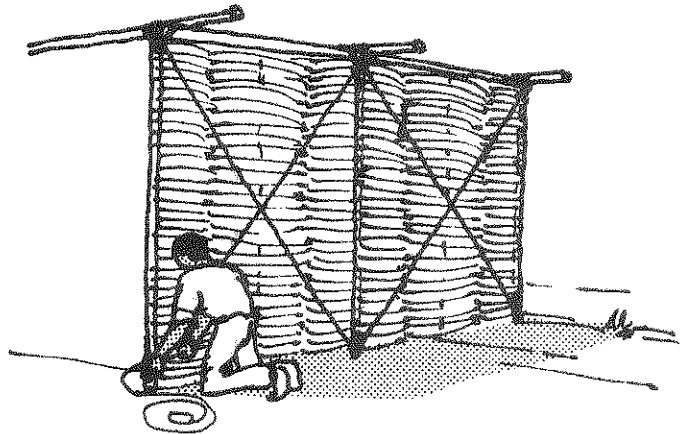

The hurricane resistance potential of wattle-and-daub, if properly built and reinforced, would be moderate. Structural performance can be improved although, due to the type of construction, the building cannot be made airtight or sufficiently strong to withstand extremely high winds (over 100 mph), and structural damage can still be expected. If all the basic rules are followed, however, a substantial improvement in safety can be attained.

7. Modifications for Earthquake Resistance: In terms of vulnerability to earthquakes, wattle-and-daub structures are relatively safe. The principal weakness is still the columns in the ground. In a strong earthquake, the columns may break and displacement or collapse of the walls will result. By following the recommendations outlined above, the earthquake resistance potential of wattle-and-daub houses can be increased substantially.

It should be pointed out that, even though extensive structural damage may result from either hurricanes or earthquakes, the potential for serious injury resulting from collapse of these buildings is relatively minor. The structures are lightweight and, because they are woven together, big chunks will not come flying off to cause major harm to the occupants.

B. Mur (Stone Nog) Construction

Stone nog houses are the most prevalent form of rural housing in the south and most new ones are built with this technique. They are found throughout the region in urban and rural areas, both on the coast and in the mountains.

1. Construction: Stone nog walls are built with a segmented wooden frame with vertical columns approximately 1 meter apart. When the frame has been erected, stones are cemented inside each section of the frame, usually with a mud mortar. As soon as one section has set, the process is repeated until the entire wall is completed. The walls rest on a stone foundation.

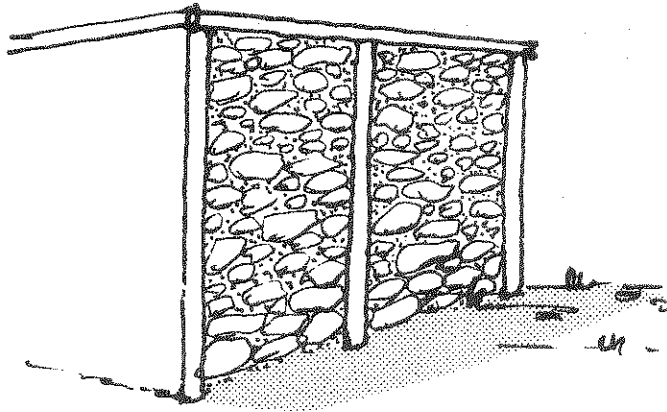

2. Roof: Mur houses usually have C.I. sheet roofs, although many still use thatch.
3. Size: Houses built in this manner are small to medium in size, between 3-4 meters wide and 5-7 meters long.
4. Vulnerability: Mur houses can be extensively damaged in hurricanes. Expected damage includes separation of the roof from the walls, failure of gables, and failure of the walls themselves. Failure of the walls is generally a result of deterioration of the mortar or wooden frame or separation of the stones from the frame due to a poor bond between the stone infill and the wood.
5. Other Weak Points: Other weak points of mur structures include the connection between the roof trusses and the wooden ring beam atop the wall and stone gables at each end of the structures with this type of roof.

6. Modifications for Wind Resistance: The following actions are recommended in order to improve structural performance in high winds:

a. Emergency measures

- Use more nails to fasten the roof sheets to the roof trusses.
- Fasten the roof rafters to the ring beam with metal straps or wire, giving special attention to the corners.
- Board up windows when a hurricane approaches.

b. Measures for improving new construction

- Add storm shutters to help close off windows during periods of high winds.
- Treat wood posts before placing them into the wall or the ground.
- Place diagonal braces in the roof frame of gabled roofs.
- Use diagonal or cross-bracing to reinforce vertical columns.

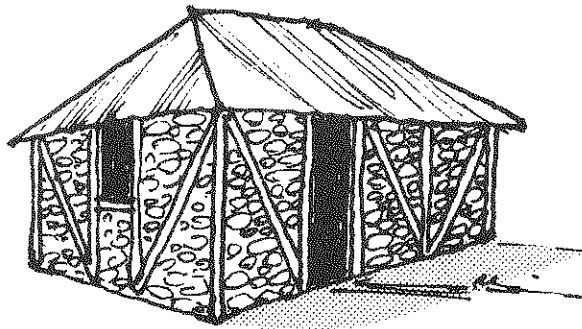

- Tie corners together by fastening a diagonal brace on- to the top of the frame.
- Build only wooden gables.

If these recommendations are carried out, the wind resistance potential of mur structures will be substantially increased. If properly reinforced, this type of building can be made wind resistant.

7. Modifications for Earthquake Resistance: Mur structures can be excellent structures for resistance to earthquakes if properly built and maintained. The most important features to consider are the connections between the walls, the condition of the wood supports, and placement of the buildings on a solid stone foundation.

C. Mélange (Spanish Wall) Construction

Spanish wall construction was introduced during the period when Haiti and the Dominican Republic were united. Because it is cheap, strong and easy to build, rural builders utilize this method.

1. Construction: In the spanish wall construction system, a wooden frame with vertical columns approximately 1 meter apart is erected. Boards are then attached to the inside of the columns and small, flat rocks are cemented vertically with a mud and lime mortar to form a section of the wall. When the section is completed, the back boards are moved to another part of the frame and the process is repeated until the entire wall is completed. A diagonal brace is sometimes placed in each corner. The upper part of the frame serves as a ring beam for the structure.

The spanish wall technique is stonger than the stone nog type of construction and is usually straighter and lighter.

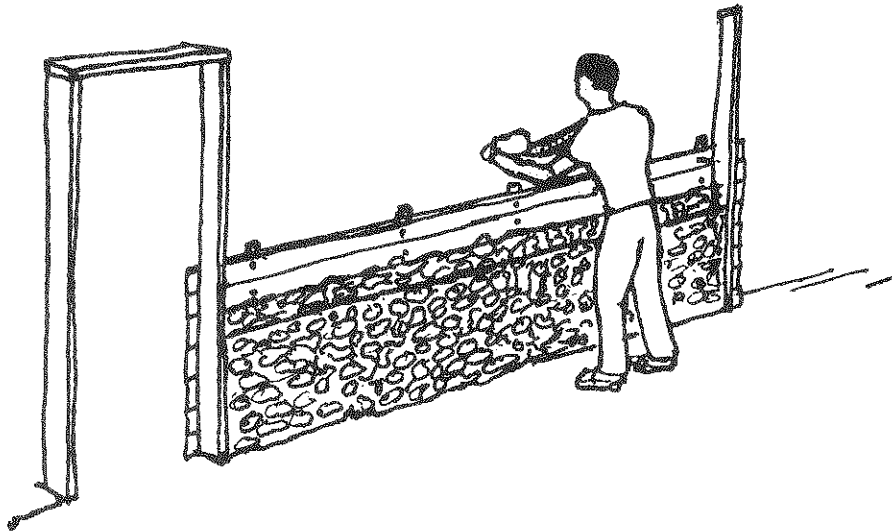

2. Roof: Spanish wall houses usually have metal roofs, although many still use thatch.
3. Size: Houses built in this manner are usually between 3-5 meters wide and 4-6 meters long.
4. Vulnerability: The strength of spanish wall houses depends on the strength of the frame and the connections between walls. Expected damage includes separation of the roof from the walls, failure of the gables, and separation of the walls from the frame. Wall failure is usually a result of deteriorated wooden columns.

5. Other Weak Points: Another weakness of Spanish wall construction is deterioration of the mortar. In high winds, weakened walls may collapse from wind gusts.

Other weak points in high winds include the connections between the roof trusses and the wooden ring beam atop the wall.

6. Modifications for Wind Resistance: The following actions are recommended in order to improve structural performance in high winds:

a. Emergency measures

- Use more nails to fasten the roof sheets to the roof trusses.
- Tie the roof rafters to the ring beam with metal straps or wire, giving special attention to the corners.
- Board up windows in a hurricane.

b. Measures to improve new buildings

- Add storm shutters to help close off windows during periods of high wind.
- Treat wood posts before placing them into the wall or the ground.
- Place the walls on a solid rock foundation.
- Use diagonal bracing in the roof structure.
- Place diagonal braces on the top of the frame in each corner to tie the walls together.
- Place cross-braces between vertical columns.

If the above recommendations are carried out, the wind resistance potential will be substantially increased. If properly reinforced, this type of building can be made wind resistant.

7. Modifications for Earthquake Resistance: Structures using Spanish walls can be made to resist earthquakes because the frames provide good support for the walls. The most important features to consider are the condition of the wood, the

connections between the walls and the strength of the foundation. Cross-braces in the walls would greatly strengthen the buildings.

D. Wood Frame Construction

Wooden houses were once very popular in Haiti, but deforestation and the high cost of wood have placed wooden houses out of financial reach of most low-income families. A few new houses are built each year where timber can still be acquired, but many now use palm boards for siding.

Wooden houses offer the advantages of ease in building, ease of adding on to the existing structure, and suitability to the climate. If maintained properly, they will last many years.

1. Construction: Wooden houses usually use a pole type of construction. This means that the vertical columns of the wood frame go directly into the ground and anchor the structure. The siding is nailed horizontally to the columns to complete the wall.

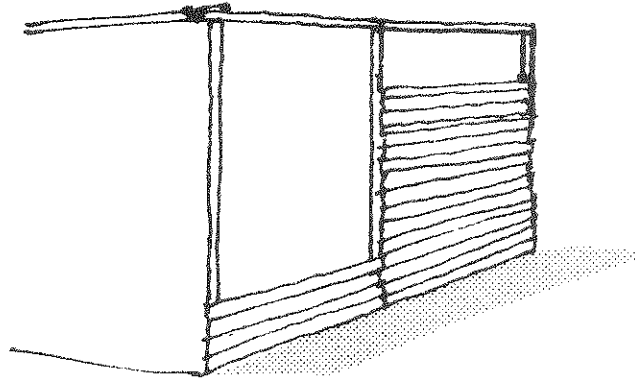

2. Roof: The normal roof covering for wooden houses is metal sheeting. Most wooden houses have two-sided, or gabled, roofs.
3. Size: Sizes vary from 3 x 5 meters to 4 x 6 meters.
4. Vulnerability: Wooden houses tend to be more heavily damaged than other types of construction. This is caused by differential pressure pushing out on the walls until portions of the walls separate at the corners.

Most houses are insufficiently anchored to the ground. Posts do not use anchoring devices and are not buried deep

enough to prevent strong winds from lifting the structure off the ground.

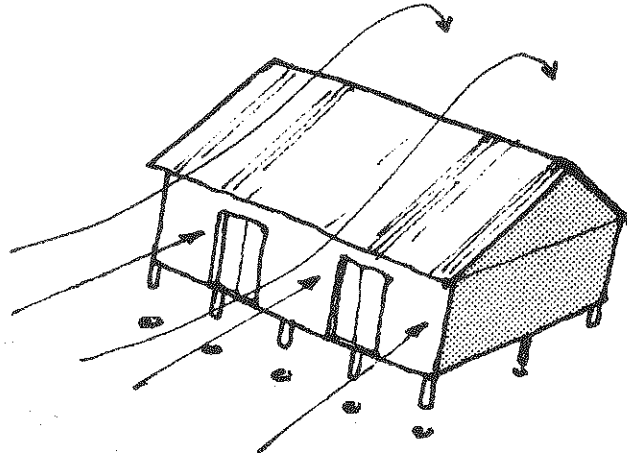

Some wooden houses built by development agencies rest on concrete blocks or piers and are not anchored to the ground. During hurricanes, the houses may be lifted off the piers and toppled over.

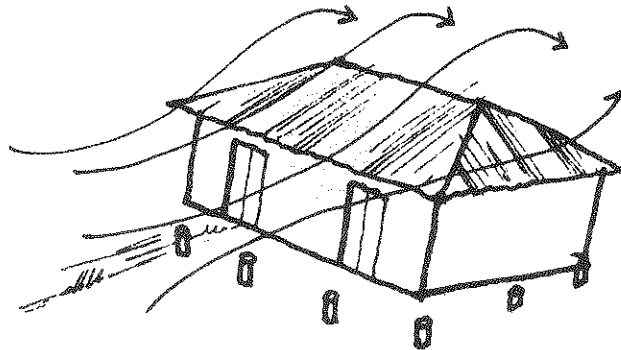

5. Other Weak Points: Typical weak points of wood frame houses are the connections between the roof sheeting and roof trusses, the connections between the roof trusses and the walls, the connections between the walls, and open spaces between the roof and walls that allow wind to enter the building below the roof.
6. Modifications for Wind Resistance: The following actions are recommended in order to improve the structural performance of wood frame houses in high winds:
 - a. Emergency measures

--- Use more nails to secure the roofing sheets to the roof frame or truss.

- Seal the area below houses on blocks or piers with stones and mud to prevent air from entering under the house.
- Use metal straps to secure the roof trusses to the walls.
- Seal the openings between the roof and walls to prevent wind from entering at the eaves.

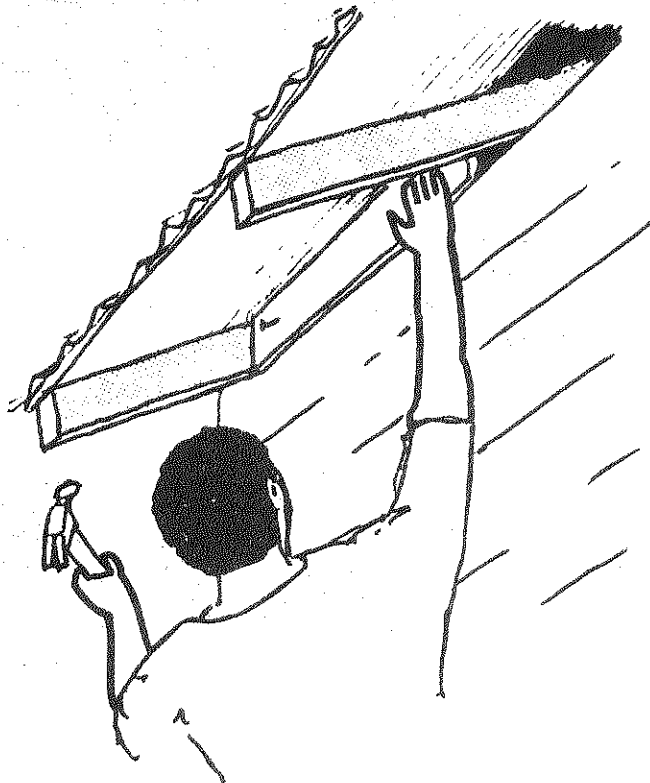

- Board up windows when a hurricane is approaching.

b. Measures for improving new construction

- Use a hipped roof configuration.
- Place diagonal braces on top of the frame at each corner to tie the walls together.

--- Place diagonal braces on the corners for added strength.

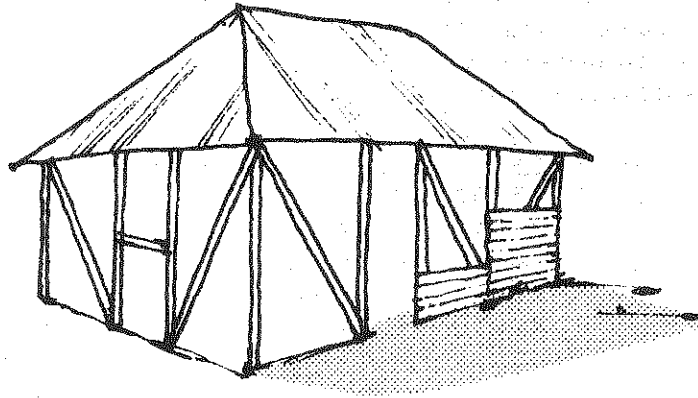

--- Anchor the structure securely by placing anchoring devices on all columns.

--- Treat all wood placed in or on the ground with wood preservative.

If these recommendations are carried out, the potential for this type of structure to resist high winds will be substantially increased. If properly built, this type of structure will provide moderate safety in hurricanes.

7. Modifications for Earthquake Resistance: The earthquake resistance of wooden housing is very good and, by following the recommendations above, the margin of safety will be increased. The only major type of damage that should occur in an earthquake would be failure of the wood columns at the base due to deterioration of the wood columns, but it is unlikely that the building would fall. Diagonal bracing and the treatment of all wood in or on the ground would make earthquake damage negligible.

E. Concrete Block Construction

If properly built, a concrete block house can withstand the forces of both windstorms and earthquakes and is the safest and most durable form of construction. Unfortunately, many houses are inadequately reinforced, use low-quality blocks and are laid with insufficient and poor-quality mortar.

1. Construction: The strength and durability of block housing is determined by the amount of reinforcement used and the strength of the bond between the blocks. Ideally, iron reinforcing rods should be placed vertically in the corners and walls at no more than 50 cm. intervals. At the top of the walls a ring beam should be made of poured concrete. Foundations are made by cementing a strong stone wall 75 cm. deep to support the wall.

In South Haiti, normal practice is to use rebars sparingly, and many owner-built houses use iron only in the corners and one in the center of each wall. Foundations are often built by cementing a course of blocks slightly below ground. This type of foundation is very weak and leads to differential settling which in turn causes cracks that weaken the wall.

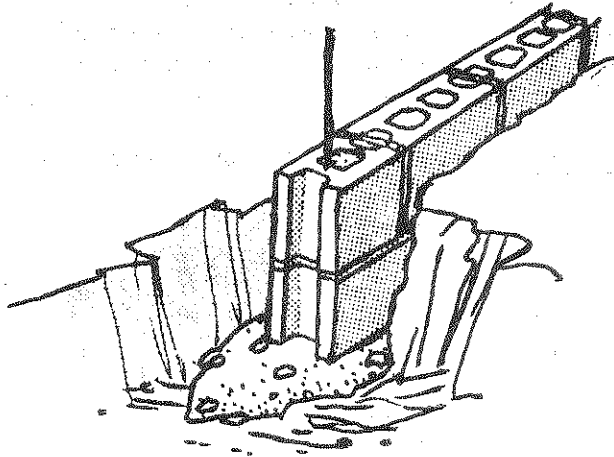

2. Roof: The roofs of block houses are covered with C.I. sheets, although more and more concrete roofs are being built. The C.I. sheets are attached to wood purlins which are fastened to the walls by bending a portion of the steel used in the reinforcing columns or ring beam over the base of the truss.

3. Size: Concrete block houses vary in size. The smallest are approximately 4 x 7 meters with the average being approximately 5 x 10 meters.
4. Vulnerability: The expected damages to a block house include the separation of metal roofs from the wall (due to poor connection of the roof frame to the wall) and failure of wall sections resulting from poor bonding of the blocks and/or an unreinforced or poorly reinforced wall. In many cases, catastrophic failures can be expected, especially in houses with concrete roofs resting on poorly reinforced walls.
5. Problems in Block Construction: The strength of masonry is a function of the alignment of the wall (both vertically and horizontally), the strength of the mortar, and the strength of the blocks. A number of faults have been noted, including:
 - a. Poor-quality blocks: This is usually a result of lack of quality control in local fabrication of the blocks and attempts to make blocks more cheaply by using less cement.
 - b. Poor mortar: There is often a tendency to reduce the cost of the mortar by using less cement in the mix. This reduces the strength of the bond. Likewise, there is a tendency to make the mortar too wet in order to make it more pliable and easier to work with. This too reduces the bonding strength.
 - c. Poor concrete mix in the structural columns.
 - d. Poor connections between interior and exterior walls.
 - e. Unlevel masonry on each course.
 - f. Insufficient reinforcement in poured columns, and insufficient use of rebars placed inside block walls.
 - g. Poor detailing in corners.
 - h. Improper or insufficient foundations.

i. Insufficient mortar between blocks.

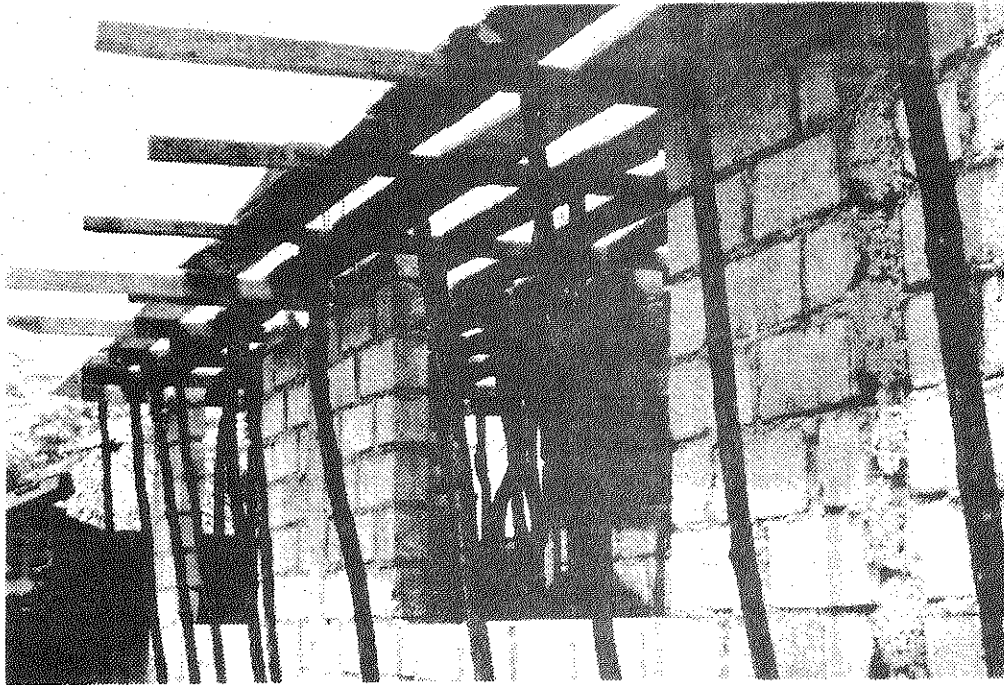

j. Excessive spans and questionable detailing of lintels above windows.

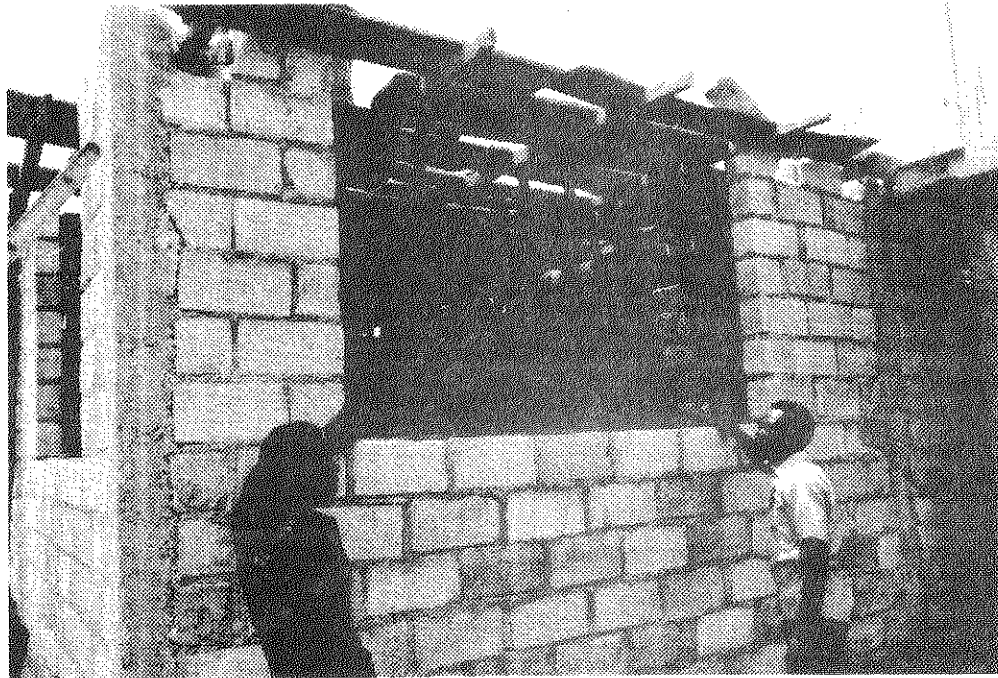

k. Improper placement of doors and windows near corners.

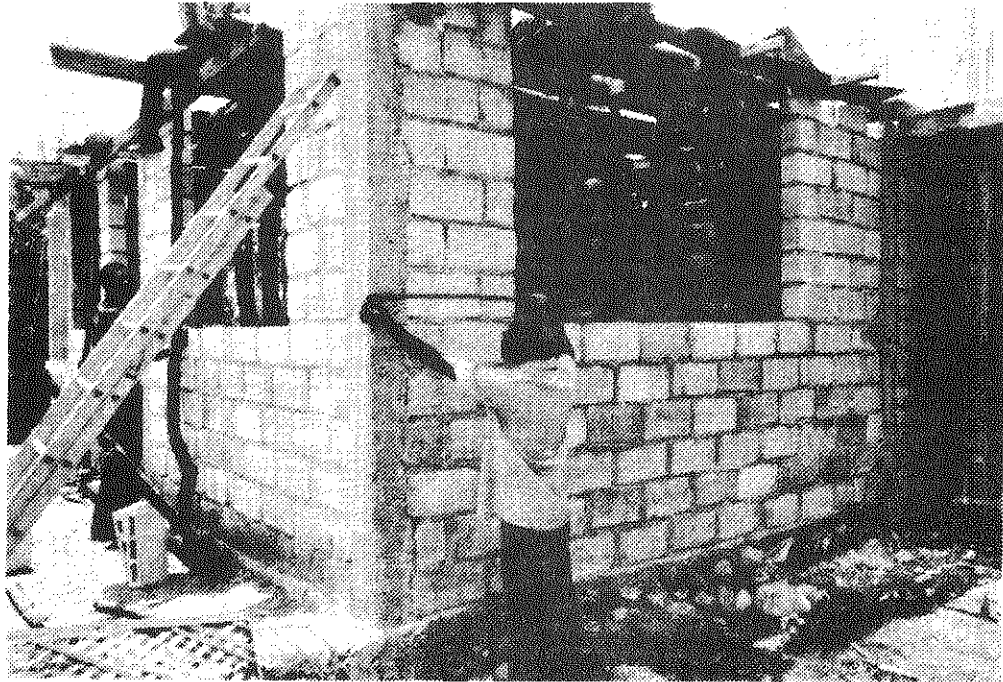

6. Modifications: In order to improve the structural performance of concrete block housing, these actions are recommended:

a. Emergency measures

- Use more nails to attach metal sheets to the roof frame.
- Seal any open spaces between the roof and the wall.
- Fasten the wooden roof trusses more securely to the ring beam of the walls by using metal fasteners, and double the number of fasteners on each connection.

b. Measures for progressive upgrading or new construction

- Use a hipped roof configuration.
- Use a roof pitch between 30°-40°.
- Design verandas so that they are structurally independent of the roof and can break away without further damaging the roof of the house.

If the above recommendations are incorporated into the design of concrete block houses, the resistance of the structures will be excellent and only minor damage should occur in windstorms and earthquakes.

V. THE BUILDING PROCESS

THE ROLE OF THE BUILDING TRADESMEN

The majority of housing in low-income communities is built under the supervision of a construction tradesman, although ajoupa and klisé houses are often owner-built. In the case of wooden houses, the carpenter will build the entire house; in most other types, carpenters working under a mason will build the frame and masons will build the stone walls. These men may or may not be full-time builders, but usually they have had considerable previous experience and are people in whom the homeowner has sufficient trust.

Once the contract has been made, construction labor may be provided in one of two ways. First, the tradesman may simply contract with other tradesmen, who usually have less training, to assist with construction. This is usually the case in the construction of houses with stone walls. Participation of family members, with the father and one or more of the sons helping, is more and more common in order to reduce costs.

A profile of the building process for most types of low-income housing is as follows:

When the homeowner decides to build a house and has acquired a site, he determines the size, floor plan and building system to be used. Then the building materials are acquired. In the past this meant gathering some wood or thatch available locally at minimal or no cost. More often now, the materials are purchased from various sources. A carpenter or mason will then be hired for a fixed price to build the house.

There are, of course, many variations in the role of the tradesman. Sometimes he will be asked to furnish all of the construction materials as well as the labor. At the other extreme, the tradesman might only be hired for a very short time to do the critical steps of erecting the frame and building the roof, while the owner completes the house. Because of the complexity of the workers' detailing and the increasing need to improvise in the use of wood components, only in the very poorest of the rural areas is it common for individuals to rely solely on their own labor and skills.

The importance of tradesmen should be taken into consideration by any agency seeking to initiate a housing improvement program. Any such program should emphasize teaching these tradesmen --- as well as the public at large --- how to build a better house. While certain general promotional activities are necessary in order to create an

atmosphere of acceptance for any proposed changes, programs that encourage self-help construction by families without the participation of a tradesman will generally find it difficult to achieve lasting changes.

BUILDING SKILLS

Building skills of Haitian craftsmen vary considerably from place to place. As a general rule, the quality of construction improves closer to the capital and other large cities. This is due to gradual migration of the more skilled workers to the cities where they can earn higher wages. The result is that many building tradesmen possess only the most rudimentary building skills, and many are unfamiliar with, or do not know how to correctly perform, basic construction techniques.

Another problem caused by the exodus of skilled builders is the depletion of tools from the rural areas. Those who have left for the cities have taken their tool kits with them and many of the poorer tradesmen are now working with improvised, self-made and generally inadequate tools. Even such basic tools as hammers, chisels and saws are in short supply, and the machete has become the major tool.

At a time when materials such as wood are in scarce supply and improvisation in construction is required, the general decline of skills and the lack of tools both contribute to the overall decline in building safety and will hamper proposed housing improvement activities. Thus, as a first step, special programs will have to be established to work with masons and carpenters to upgrade their construction skills and to teach them how to make and use basic tools.

CARPENTRY SKILLS

Carpentry and woodworking skills are important factors in Haitian housing because wood frames provide the structural strength of all except block building systems. Outwardly, the fancy woodwork on many houses and the care given to certain wood joints would indicate a good knowledge of carpentry. A closer look, however, reveals that many of the joints have little strength. The drawings on the next pages illustrate some common problems. Braces are often attached in such a way that they will only hold in one direction, and nails are often placed so that they split the wood or are put in places that add little strength to the connection. Wood splices, especially in small poles used as columns, rarely are reinforced and will not resist even minor wind loads.

Of particular concern are the following:

- A. Vertical Alignment of the Building Frame: Many rural houses that use wood posts are erected with these posts out of vertical alignment. This means that a portion of the weight is off-center when a hurricane places additional loads on the walls; thus, the possibility of collapse is increased. While the use of unplanned, rustic wood makes it difficult to completely overcome the problem, certain basic skills that can help reduce the severity of the problem can be demonstrated (such as the use of a plumb and lowering the center of gravity).
- B. Joints: A key problem in many of the wooden joints is the lack of friction between wood pieces. This is especially a problem where posts of unplanned rustic wood are used.

Joints such as the one demonstrated below are commonplace.

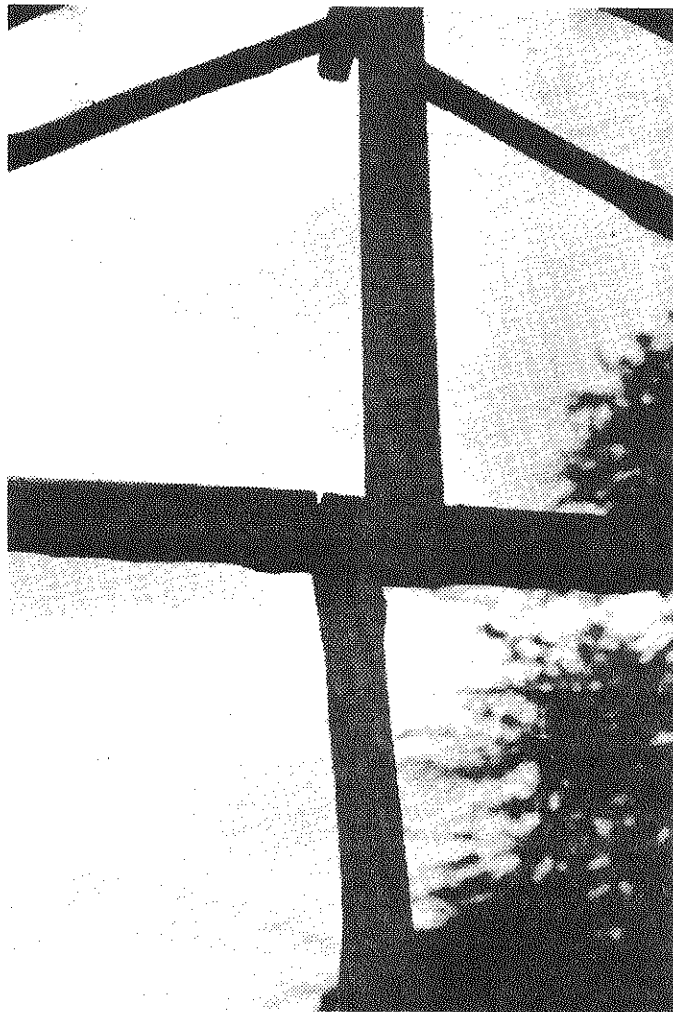

Simple techniques for shaving and squaring the wood to increase the strength of the joints should be demonstrated.

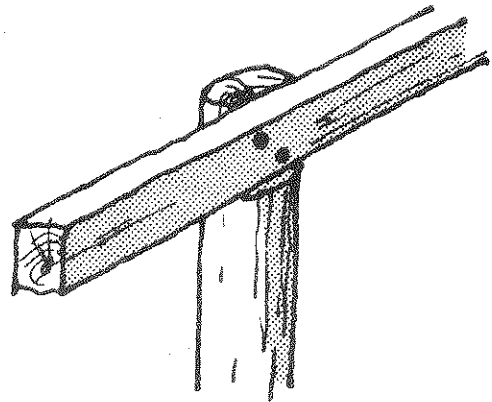
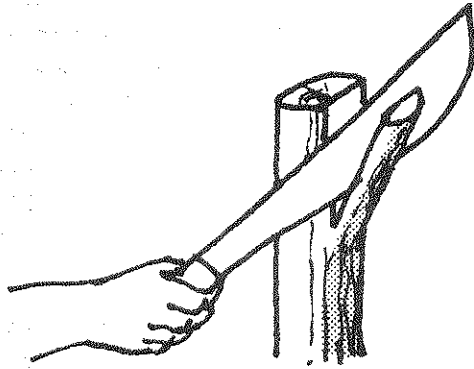

Nails are often depended upon to fasten one piece of wood to another. Often wood that is structurally important is nailed in tension rather than shear. When forces are applied, the nail will slip out and separation will occur.

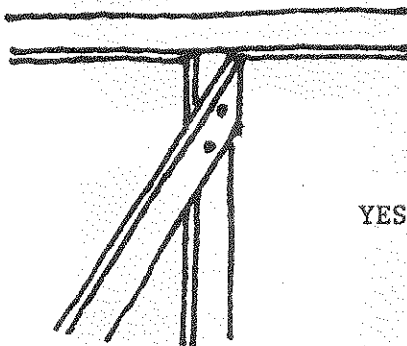
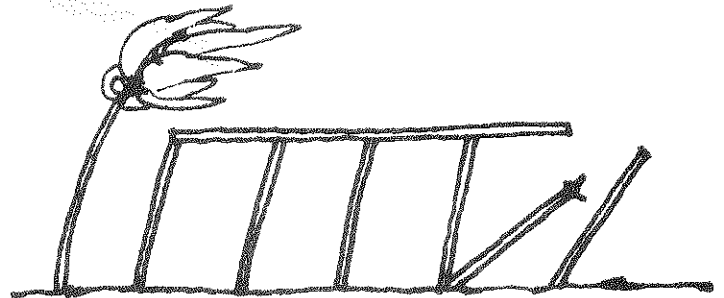
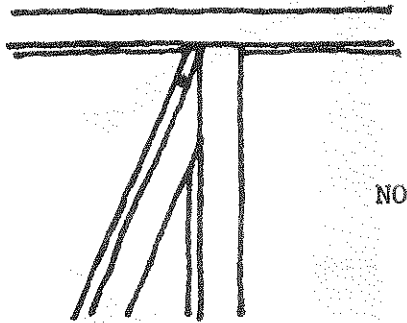

Another problem concerning nails is that they are often too large for the wood and split it. Simple techniques for determining the proper size of nail and methods for reducing

splitting (such as flattening the tip of the nail as shown below) can help strengthen the joints and reduce wood damage.

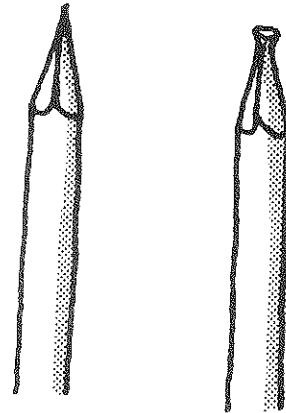
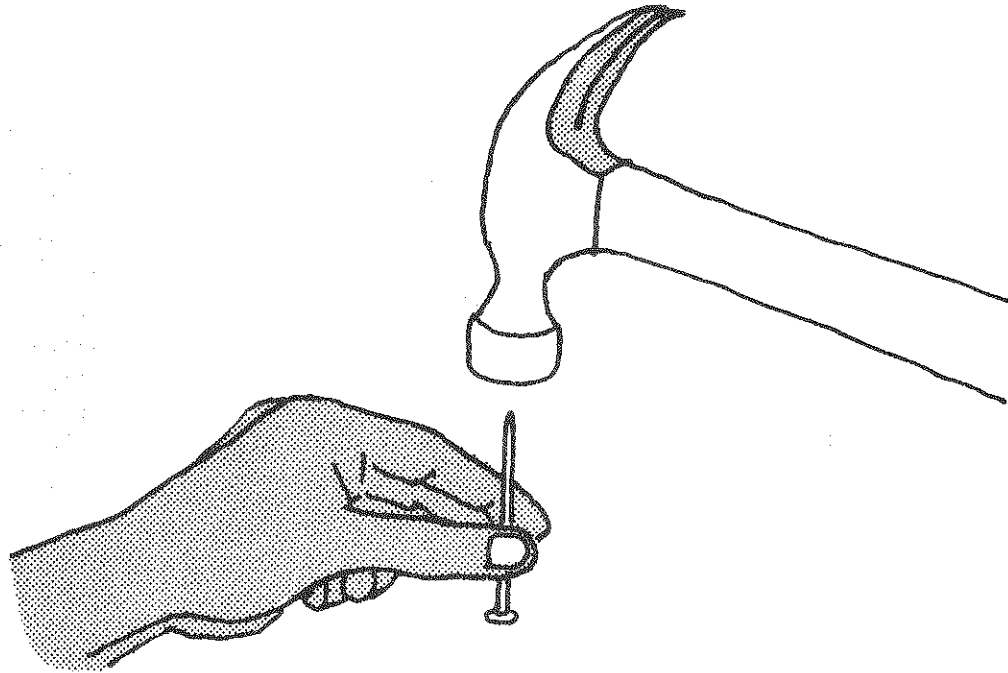

BEFORE

AFTER

- C. Splicing: Splicing (the connection of two pieces of wood to make one continuous piece) is a major problem area, especially in houses that use rustic wood. Many splices are

held together only with a nail. Few use joints that would add strength to the detail.

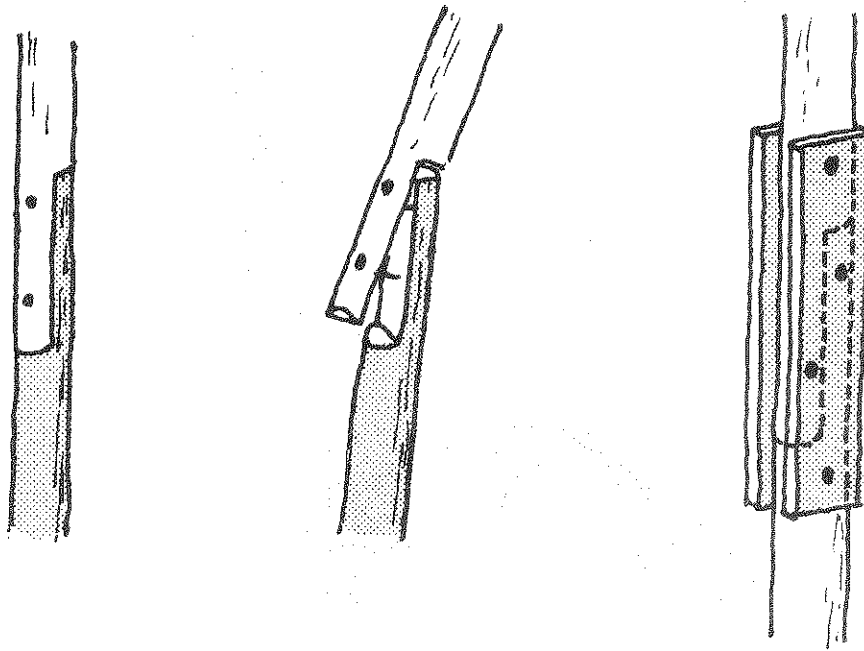

Another problem is that spliced columns are often used. This should be avoided whenever possible for in all probability they will fail. If they must be used, the splices should be reinforced as shown below.

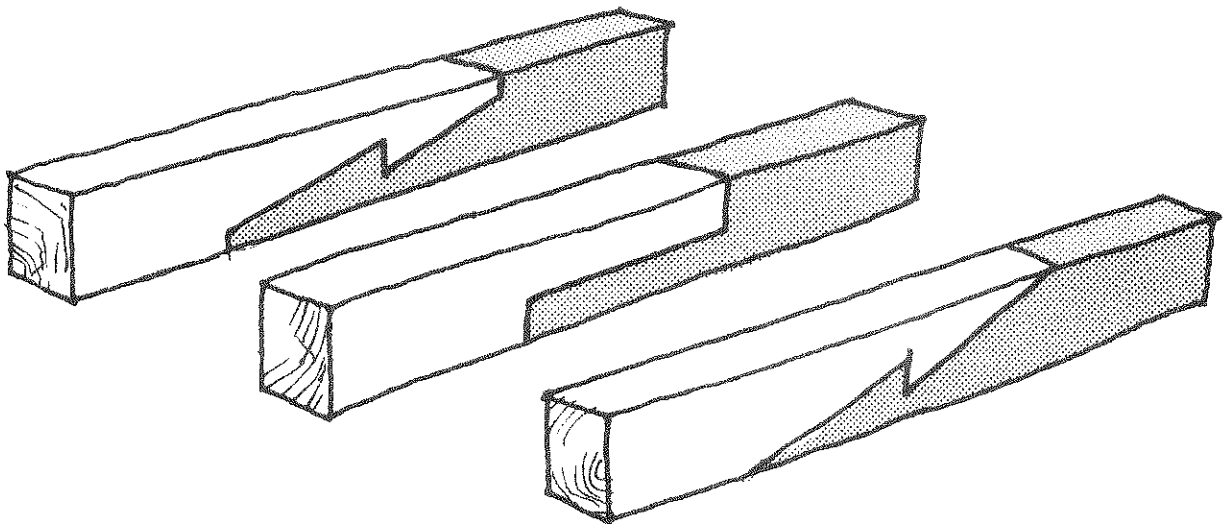

- D. Poor Connections Between Wood and Stone Masonry: A common problem noted in mur and mélange construction is the poor quality of connections between wood posts and stone masonry infill. Unless the masonry is firmly attached to the frame, the walls will separate and collapse. A simple method for attaching infilled stone walls such as imbedding nails in the mortar, adding wire to the frame, and providing more strength to the frame itself (as shown below) should be taught.

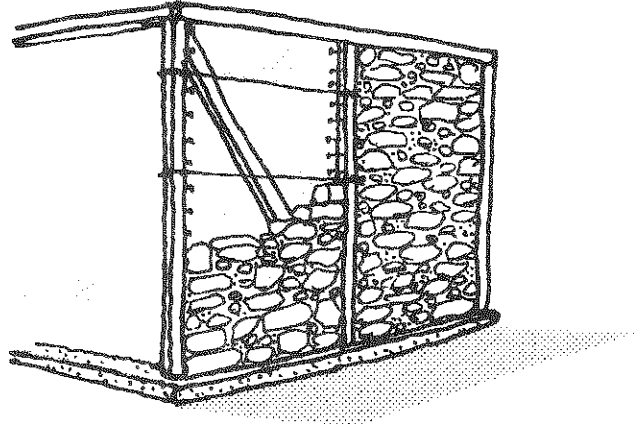

- E. Wood Preservation: A problem common to many of the houses built in the last decade is deterioration of the wooden components. Due in large part to the use of softer woods (mentioned earlier), the problem is especially critical in columns placed in the ground. In Hurricane Allen, many columns broke at ground level because they were rotten. Unless the wood is properly treated when it is placed in the ground, little can be done to improve the overall resistance of the building to high wind forces.

The cost of wood treatment is relatively minor and many low-cost methods are available. One effective measure is to char the portions of the wood that will be placed in the ground. By burning a protective charcoal barrier around the base, the wood will be protected from insects (they will not eat through charcoal).

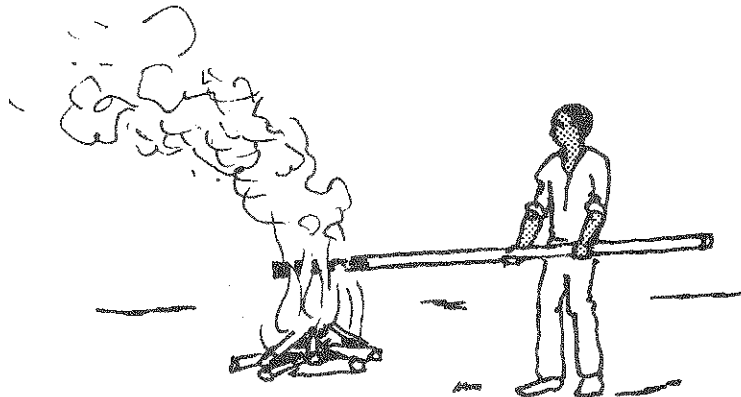

Other effective low-cost measures are immersion of the wood in a bath of crankcase oil (adding an insecticide such as aldrin or dieldrin can further increase the effectiveness of this method) and thorough painting of the exposed surfaces with such commercially-available wood treatments as creosote or pentachlorophenol.

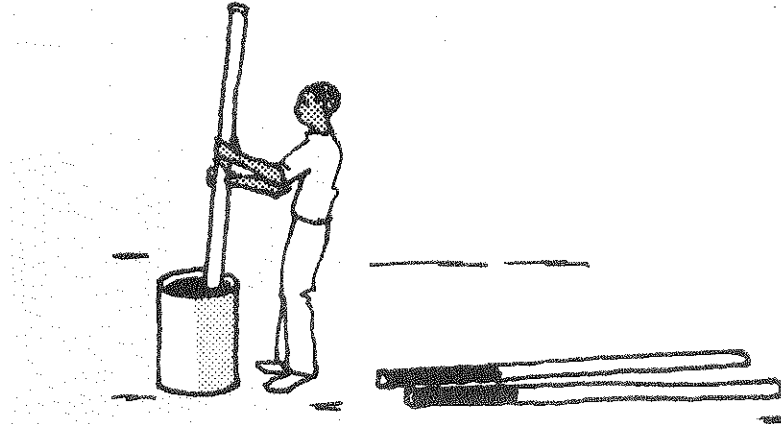

F. Poor Use of Bracing: Where attempts have been made by carpenters to reinforce the building frame, the braces do not provide adequate strength. Common problems include:

1. The placement of braces in tension held on by nails where they can easily separate.

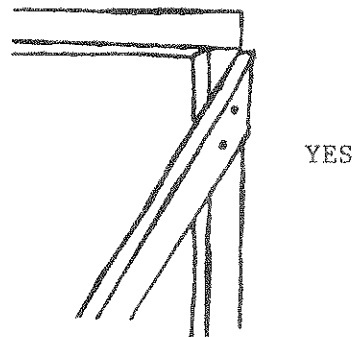
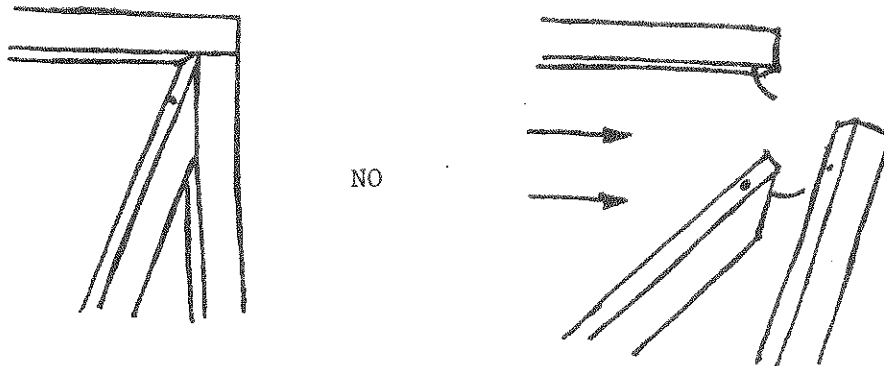

2. The placement of braces at angles that are insufficient to provide adequate rigidity or resistance, and the placement of supports in such a manner that they do not adequately carry or distribute loads.

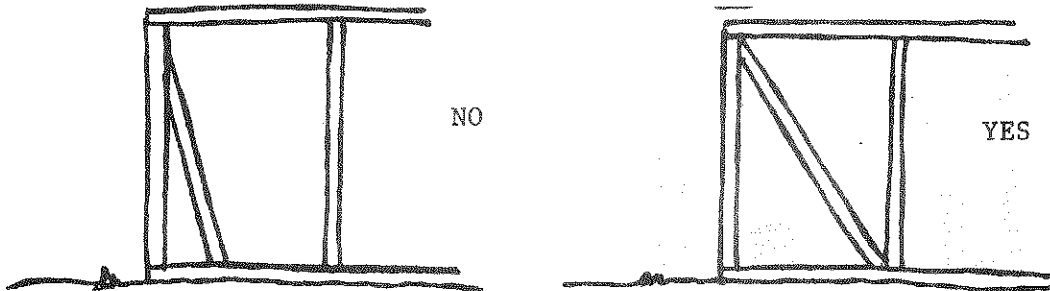

A general explanation of the principles of reinforcement and distribution of loads should be part of any program designed to improve basic building skills.

STONE MASONRY SKILLS

The strength of a masonry wall depends on:

- The strength of the primary material (the size and strength of the stones);
- The strength of the mortar;
- Whether the walls are vertical (they should not lean);
- Whether the walls are straight (they should not bulge or wave);
- Whether each course or layer of the walls was laid evenly and allowed to set properly before the next course was added;
- Whether the lower part of the wall has sufficient strength to hold the upper portions (generally bigger stones should be placed at the bottom of the wall); and
- Whether the foundation adequately supports the walls.

Various problems in stone masonry were consistently noted. Many walls bulge outward in the center. This is due to the fact that many

masons do not use guidestrings when laying the walls. When guidestrings are used, masons often place each block on the course immediately adjacent to the guidestring. Thus, each block pushes the string further out and, by the time the course is completed, the wall bulges out from the true course of the line. The proper technique for utilizing a guideline in masonry work should be demonstrated.

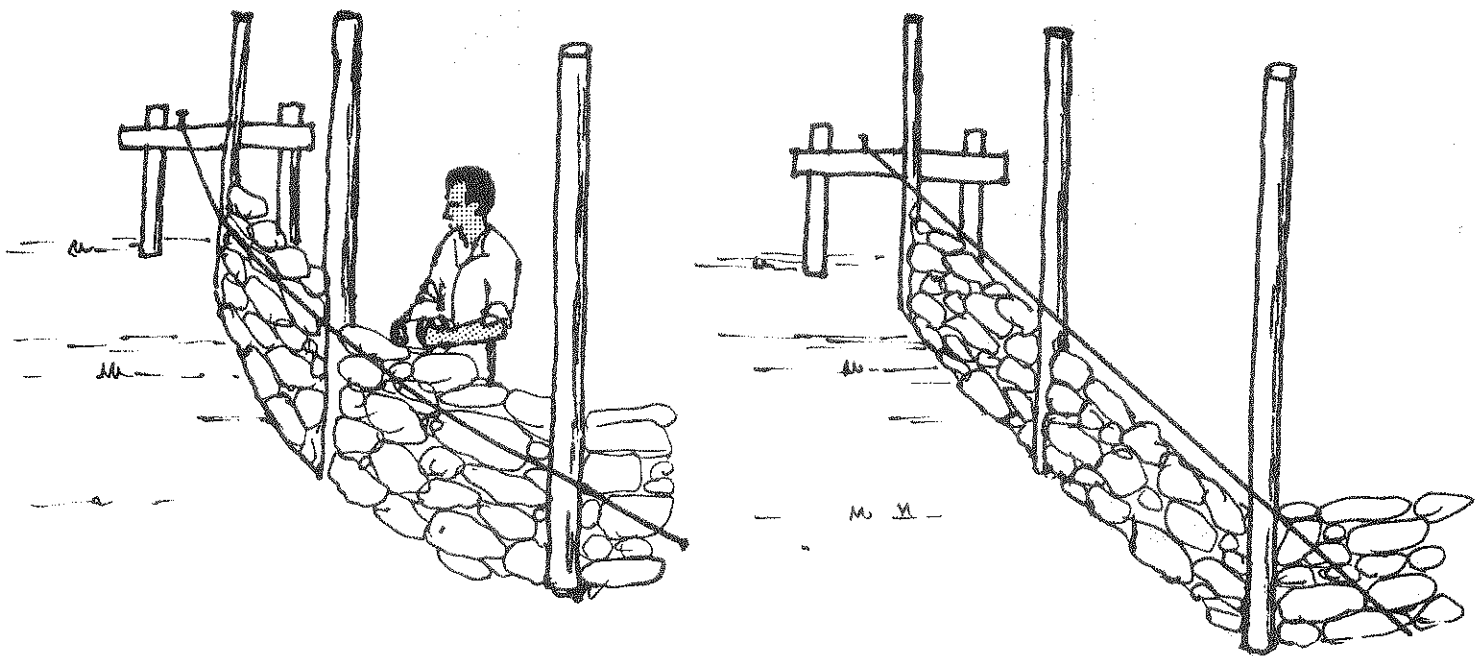

As mentioned earlier, many walls lean outward, mostly because the wood columns are not straight. But even when the wood is straight, walls still lean. This is due to a lack of understanding of how to build a wall vertically and how to use a mason's plumb and level. Masons should be shown how to make plumbs and levels, and the proper techniques for using them should be demonstrated.

The foundations of many masonry buildings are not strong enough to support the walls. Added strength can be achieved by deepening the foundations, modifying the design, and bonding foundation stones with a stronger mortar.

A stone masonry building technique that should be introduced as a means of reducing costs and reliance on wood is the use of pilasters. Pilasters are structural columns made of stone. They are placed at key locations, like the corners, and at regular intervals in the walls, in order to help reinforce the building. They are

simple to build, do not require any additional skills, and add much strength to small buildings.

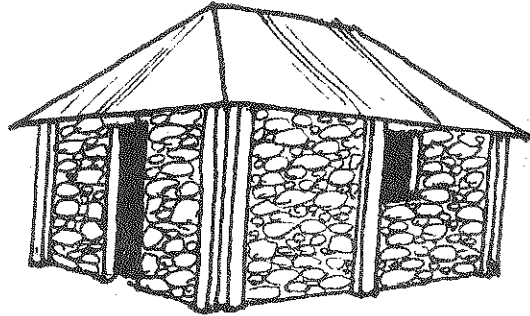

CONCRETE BLOCK MASONRY

In addition to the problems in block construction listed on pages 45-47, other deficiencies in block masonry include bulging and leaning walls. As in stone masonry, these problems are a result of poor lay-up work such as:

--- Improper use of guidestrings for alignment;

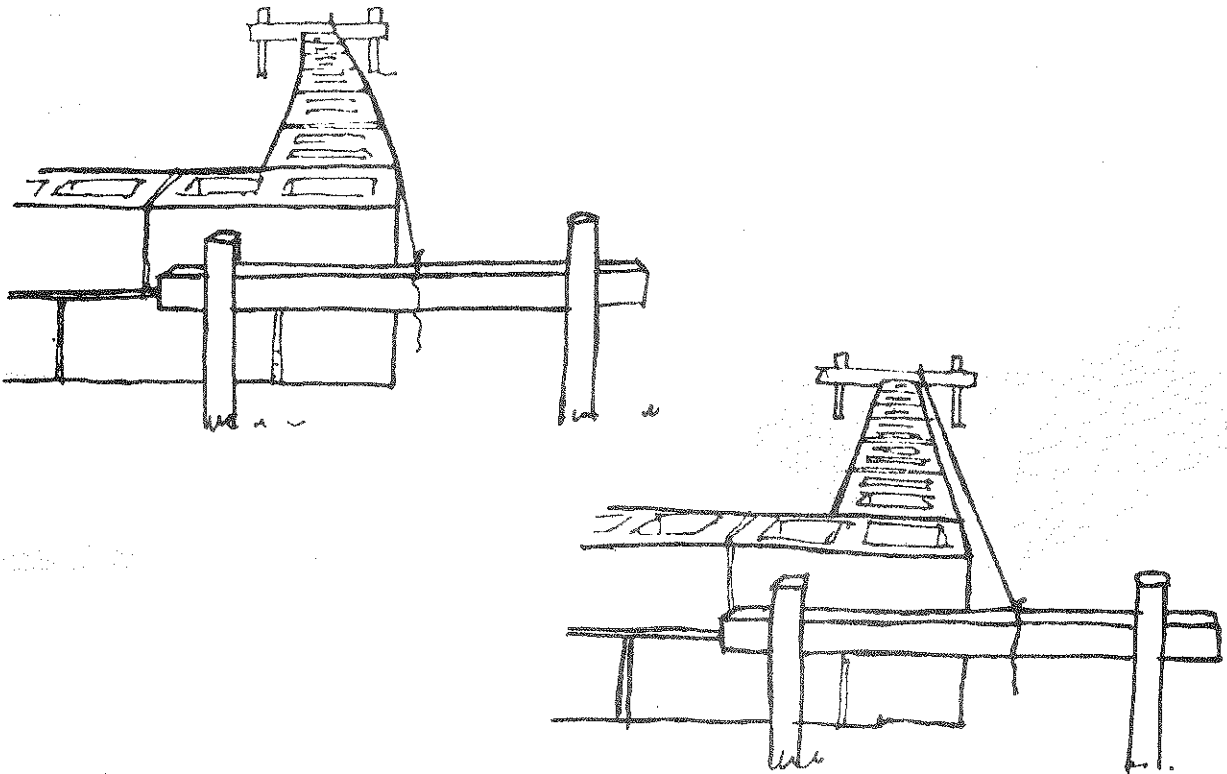

--- Improper use of levels for laying each course;

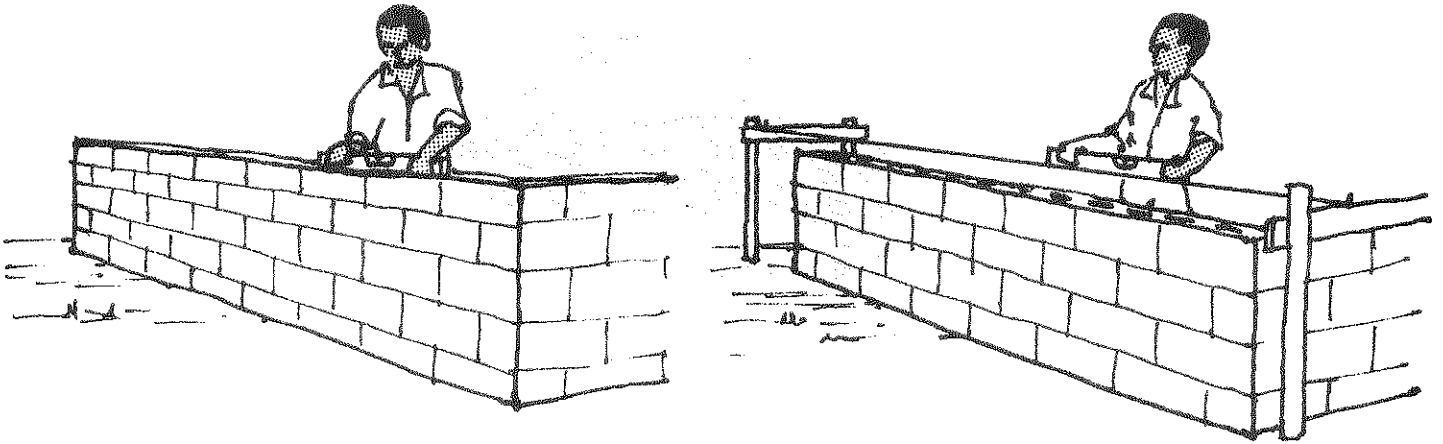

--- Improper use of plumb for checking vertical alignment.

Each of these problems can be solved with the proper tools and training.

Illustrated below is a means of reducing costs in block construction that relies on a combination of indigenous materials and block to form a strong, modern-designed house. Blocks are used to form the corners and center of the house while stone masonry is used as an infill for the majority of the walls. This system, which is being introduced on small islands in the Pacific, is both strong and relatively low-cost, and it offers a suitable alternative to and a step-up from wood frame masonry systems.

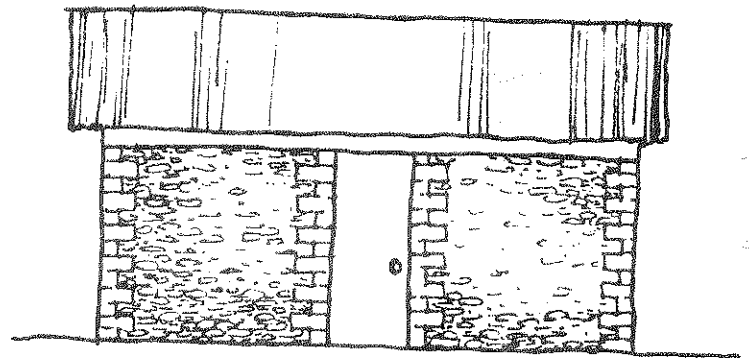
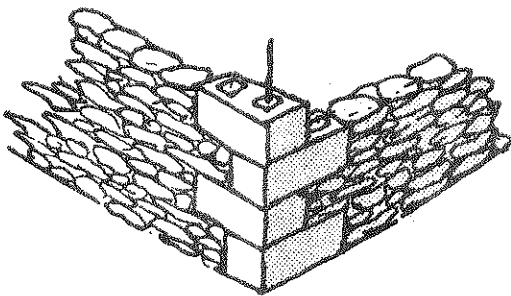

FINANCING

There are no financing mechanisms available to the majority of very low-income rural dwellers. Construction commences when the family has obtained or saved the cash necessary to purchase materials and hire labor. There are few options on materials; usually the least expensive that are locally available are chosen.

VI. TRENDS AND PROBLEMS IN THE HOUSING SECTOR

TRENDS

In the next decade, the decline in the standard of housing and corresponding increase in vulnerability can be expected to continue. This will be a result of over-population, decreasing wood resources, and the increasing poverty resulting from the country's inability to cope with basic development issues. Thus, as the cycle of poverty continues, more people will have to deal with less.

In the housing sector, as wood becomes less and less available, people can be expected to attempt to build heavier housing using larger and thicker stones so that the walls can stand without wood supports. If buildings made in this way use cement, they will be quite safe. But since cement and lime are considered very expensive by the rural poor (as well as being generally unavailable in many remote communities), it is more likely that mud mortars will continue to be used, resulting in fairly weak walls. Another problem in the first generation of these new designs will be poor roof-to-building connections. In the types of buildings now used, a wooden beam forms the top of the wall and the roof can be fastened to it. If a wall is constructed entirely of masonry, the roof rafters will in all likelihood be placed in the wall. If this is done improperly, the roofs (which experience more high wind forces than any other part of a house) are likely to fail at this point, severely damaging the walls and endangering the occupants of the house.

For upwardly-mobile families, the preferred building material is concrete block. In rural areas, only a very few families (usually those along the major roads) build with block; but, in the towns and the capital where people have less access to natural materials, more and more people are building block houses. Numerous small enterprises have been set up to produce blocks, some using handmade moulds and presses, and the quality varies considerably. Block houses are still very expensive, so the factories often attempt to cut costs by reducing the amount of cement in the block and builders reduce costs by using minimal amounts of mortar between blocks and only minimal, if any, reinforcement. Block buildings made in this manner are very dangerous in hurricanes and earthquakes. A major task facing planners will be to develop and introduce low-cost, self-help building systems to provide safe housing for urban dwellers who expect and prefer block buildings.

Land issues can also be expected to have an effect on increasing the vulnerability of housing. As farms get smaller and smaller due to over-population and subsequent subdividing of existing farms, the availability of good growing areas will be reduced. Farmers will

naturally keep the best land for crops and new houses will be placed on marginal, untillable sites. Many of these will be exposed areas on steep mountainsides. The buildings will be more exposed than before to high winds and, because they are likely to be weaker structurally, more injuries can be expected. Furthermore, many of the sites themselves are at risk from mudslides in hurricanes and heavy rainstorms.

Expansion into the marginal areas by small farmers and landowners results in further decreasing housing opportunities for the landless peasants. Previously, marginal areas were undesirable and the landless could occupy the lands without fear of being removed. Over-population and land subdividing traditions have created a competing demand for this land with the result that the landless can no longer be sure that they will not be displaced. This in turn means that they are unwilling to build secure houses or to make improvements in their buildings for fear that the investment will be lost. Thus, the landless tend to live in lightweight, makeshift buildings on sites dangerous and virtually impossible to protect, and they are among the most at risk and vulnerable groups in the country. Little data is currently available about these people; for vulnerability reduction efforts to be complete, more information on their patterns of living and settlement should be gathered.

IMPACT OF AGENCY HOUSING AND RECONSTRUCTION PROGRAMS

There have only been scattered efforts to provide housing in the south and few of these have focused on rural families. Most of the housing efforts of voluntary agencies have been conventional housing projects: i.e., land is acquired; one or two designs are selected; a contractor is hired; and the houses are built. The new owners receive the buildings free, at very reduced prices, or on a rental basis. Most houses are block. An example of such a project, funded by CRS to house victims of Hurricane Allen, is shown below.



While these buildings are undoubtedly strong and well-made, they cost more than 10 times what people can usually afford to pay for housing and thus could not be replaced by the average family without assistance from an agency. A problem is inadvertently created whenever an agency provides housing of this type below normal cost; it creates rising expectations that cannot be met. While the short-term objective of giving a few people better housing is laudable, it is the opinion of the consultants who prepared this report that, in the long run, self-help housing will be the only practical way of meeting new housing needs at a price that people can afford. Thus, agencies should use their resources to develop and promote improved self-help housing and focus more on ways to improve existing building systems.

VII. ANALYSIS OF THE POTENTIAL FOR HOUSING MODIFICATION

METHODS FOR IMPROVING HOUSING

Housing improvement includes four activities. They are:

- A. Design Changes: the altering of the design of the structure before it is built to make it more disaster resistant. Design changes are usually the least expensive form of housing improvement but apply only to new construction. For the design changes to become a part of the normal building practice, housing education efforts must be concentrated on local building tradesmen.
- B. Retrofitting: the process of installing additional supports or components in a building already erected in order to strengthen the structural integrity of the building. If the support or component can be attached to the building without reconstruction, the retrofit would be relatively inexpensive; but if a wall must be opened in order to place the component, the retrofit could be rather expensive and difficult. Retrofitting can usually be accomplished on an aided self-help basis.
- C. House Modifications: the altering of the basic configuration of a house once it has been built to make it better able to withstand external forces. Modification activities could include changing the pitch of the roof, reducing the height of the walls, or adding a room. Housing modification is usually considered expensive and requires extensive technical supervision.
- D. Conversion: a change of materials used for the walls or roof of the house. The most common conversion is a change of roof covering, usually from thatch to corrugated metal sheets. Conversions can be a means of improving the durability of a house and its disaster resistance potential at a moderate cost. An opportunity to convert materials has also been shown to be an excellent incentive to participation in housing improvement activities. Conversions can usually be carried out on a self-help basis.

ECONOMIC CONSIDERATIONS

There is a point beyond which families in each income group are unable to participate meaningfully in any housing improvement activities. In order to determine where those points are, and how appropriate strategies can be developed to encourage broader participation at every income level, it is important to identify the reasons why a family will modify or improve their house and under what conditions they will be willing to do so.

An improvement in housing can be viewed as an investment in either time, materials or money in the building. For a family to be willing to make a further investment in their house, they must:

- View the structure as permanent;
- View the structure as having some value;
- Perceive a threat to the structure or to their safety.

If these conditions are met, a family must then also have surplus income to carry out the modifications or access to credit, materials or other assistance.

Under present economic conditions in Haiti, it is doubtful that many people would be willing or able to upgrade their housing without extensive assistance. Due to the extreme poverty, housing must, by necessity, receive a low priority. Furthermore, few families realize the effect that the rapid deterioration of existing buildings has on their personal income, and those that do feel powerless to react. In regard to hurricanes, most people realize that their houses would not be safe, a fact reflected by the statements of many that they would "go to the church if a hurricane struck" (an action that should be discouraged due to the poor quality of most of these buildings). The recognition of the threat, however, does not provide sufficient motivation for most people to improve their buildings. Thus, any upgrading of the housing to withstand disasters must be a by-product of upgrading for other reasons such as increasing the life of the house, reducing maintenance costs, or increasing the value. But before this can be done, people must be made aware of how poor housing contributes to their poverty and the decline of their expendable income.

The ability of families to improve their housing is also dependent upon the availability, at an affordable price, of the necessary materials and components. Ideally, housing improvement measures should cost as little as possible. With each structure, however, there may be a point beyond which safety cannot be reasonably assured without installation of additional, relatively expensive components.

Whether the cost of these components is affordable to the homeowner is relative to the economic status of the family. What may be a high-cost option for one group of people may be a low-cost option for others.

Housing program planners can use the provision of increased access to highly desirable materials or components as an incentive to encourage housing modification. For example, corrugated metal roofing sheets, which are considered desirable by many families, could be offered along with other low-cost components (such as hurricane fasteners), to further strengthen their buildings. In some cases, the provision of scarce materials such as wood columns may be enough incentive alone for people to acquire and use the material.

Program planners should therefore consider a variety of methods for reducing the cost of building materials in rural areas. Among the various possibilities are:

- Subsidies
- Collective purchases
- Local manufacture
- Material trade-ins (the purchase by the housing agency of materials such as wood that are being replaced)
- Payment of transport costs

The lack of skilled builders is a third obstacle to vulnerability reduction. Even if people can be motivated to upgrade their houses and the necessary materials can be supplied at a reasonable price, a corps of trained builders to undertake the construction and/or to advise homeowners is not available. Thus, builders must be trained. It will probably fall to the private, non-governmental agencies to provide the necessary training. At present, however, only a few NGO's are working in the housing sector and none of these are currently training builders or working in self-help housing.

SOME POSSIBLE APPROACHES TO HOUSING IMPROVEMENT

Because of the enormity of the problem and the various obstacles that must be overcome, no single approach can be selected that will meet all the needs. Ideally, the government should take responsibility for developing an integrated and comprehensive approach to housing improvement and vulnerability reduction; but unfortunately the government's capacity in this field is inadequate and the private

agencies, already overburdened, will have to take the major share of responsibility if anything is to be accomplished. Given the limitations, competing priorities and other constraints, program options must be modest. With these considerations, the following approaches could be used.

- A. Contractor Training at A.T. Centers: There are a number of appropriate technology centers located throughout the south that offer a variety of training programs. While no contractor training programs currently exist, the centers could provide an excellent locale for comprehensive housing construction training. Courses could be initiated on tool-making, basic building skills and advanced construction techniques. If such programs were initiated, the centers could slowly introduce better building methods and serve as a training arm for housing programs of other agencies.
- B. Expanded IRDP's: Several agencies have the capacity to undertake comprehensive integrated rural development programs (IRDP's). AID, the World Bank or other large funding organizations should be encouraged to support the operational agencies that include housing improvement as a component of an IRDP. A combination of self-help and contractor training would be needed.

The advantage of using an IRDP is that a large number of people would be exposed to better housing methods at one time. It has been shown that, in order for a change to become an established norm in local building practice, a certain minimum number of families must utilize the improvements in their houses. This number is critical for two reasons. First, few families in traditional societies like to have a house that is "different"; therefore, building or installing modifications to a significant number of houses lessens the reluctance to be "first". Second, in order for local craftsmen to continue a new practice, it must become routine and the various adaptations required by different structures, materials and circumstances must be worked out. By using new or modified techniques in a fairly large number of buildings, the craftsmen are provided with adequate opportunities to work out these details, and using the new methods becomes routine.

The actual number of buildings required to attain this "critical mass" cannot be precisely determined and varies depending upon the community, location and type of improvement that is being proposed. As a general rule, in larger communities where housing is fairly concentrated and communities are fairly close-knit, approximately 5% of the

buildings should be modified in order to initiate a continuing process. In areas where the housing is more dispersed and there is less communication between families, the required percentage would be much larger. (In these areas, program planners should concentrate on houses in highly visible locations, for example, along major roads or pathways, or near where people gather periodically for events such as weekly markets.) An IRDP is the best program approach for achieving these numbers for it provides the people with economic as well as housing opportunities.

- C. Housing and Reforestation: Limited changes in housing with wooden components could be achieved by adding a housing education component to reforestation programs. In order to accomplish this, however, current reforestation schemes must be expanded to include construction-grade timbers.
- D. Housing Programs: A possible approach would be to develop housing programs specifically for improving housing. A number of program models exist but, as a general rule, housing programs that are not integrated with economic or other development activities are only successful in large urban areas. In southern Haiti, it is doubtful that such programs could be carried out.

VIII. RECOMMENDATIONS FOR HOUSING IMPROVEMENT

The following are suggested activities for improving housing in southern Haiti. The objectives are to introduce safer construction techniques and to establish these techniques as part of the normal building practice.

The quality of housing in the rural areas cannot be upgraded unless a fairly comprehensive approach is taken. Most important, vulnerability reduction activities in the housing sector must be seen as part of an overall development strategy and linked to other community-wide development activities such as reforestation. Special attention must be given as well to making people aware of how poor housing contributes to their poverty and how, by improving their housing, they will not only be safer but will also be able to reduce the amount of money they must devote to housing in the long run.

OBJECTIVES

The objectives of housing improvement activities should be:

- A. The improvement of traditional housing in such a manner that the overall costs of housing to the homeowner can be reduced.
- B. The introduction and establishment of safer building methods which are affordable to the poor in rural areas.
- C. The creation of sufficient activities and improvement of a sufficient number of houses which utilize the new building techniques, in order to provide adequate training and establish the continuing use of these techniques and procedures.
- D. The establishment of local, ongoing resources and centers of information about housing so that housing improvement activities can be perpetuated.

METHODOLOGY

In order to implement housing improvement activities, four tasks must be completed.

- A. The first task is to select and train the organizations that will implement the activities. Because few organizations currently have programs in all regions, it will be necessary to identify a number of organizations that can help to

implement the proposed activities. One of these groups should be chosen as the coordinator. The coordinator would be responsible for promotional activities, for standardizing the training of builders, and for developing and maintaining a technical reference library.

- B. The second task is the development of strategies to reduce the costs of housing improvements. Specific activities should be aimed at involving locally-based institutions such as co-ops or savings-and-loan associations. Methods for lowering the cost of building materials and tools (e.g. subsidies and tool banks) should also be explored.
- C. The third task is to set up an ongoing program to train local builders in how to use better building techniques. This will require a combination of training approaches, including:
 - 1. Theoretical training;
 - 2. "Hands on" practical training and demonstrations;
 - 3. Construction of model houses;
 - 4. Provision of opportunities for building with the new skills acquired, after the initial training, so that the builders can practice and develop confidence in their abilities. Limited supervision should be provided.

The curriculum for the training program should include instruction on:

- Tool-making
- Proper use of basic construction tools
- Design and configuration of buildings
- Cost estimating
- Site selection and development
- Proper layout of a building on the site
- Preparation of building materials (wood treatment, etc.)
- Design and construction of foundations
- Carpentry skills and techniques (including joints and splices)
- Masonry skills and techniques
- Proper bracing methods
- Improved roofing techniques
- Basic hurricane resistant construction techniques
- Advanced hurricane resistant construction techniques
- Detailing of doors, windows, basic utilities

D. The fourth task is to develop public awareness about the need to improve housing and how improvements can reduce costs. Promotional activities should be linked to ongoing development programs and reforestation efforts. A variety of public information methods could be used, including:

1. Discussions at general community meetings of development programs
2. Public meetings
3. Posters and billboards
4. Radio programs
5. Programs for school children
6. Newsletters (e.g., Bon Nouvel)

Sample media that can be used for information dissemination are:

- Posters
- Comic books
- Standardized cassettes that can be played on local radio stations
- Brief films and film strips that can be shown at community meetings.

TARGET GROUPS

In order to increase the effectiveness of overall improvement activities, those groups most likely to be building new houses should be identified and promotional efforts should be aimed initially at these groups. The following groups should receive priority:

- A. Young People Between the Ages of 18-30: This is the primary group involved in construction of new housing. Promotional activities should stress the long-term advantages of investing in housing improvements, and promotional media should depict people in this age group.
- B. People Moving to Towns: Emphasis should be given to this group because they will be building new homes.

- C. Families Participating in Integrated Rural Development Programs: These people may be in a good position to build new houses or to modify their existing structures.

COST REDUCTION STRATEGIES

In order to make housing improvement activities more desirable and thereby increase participation, a number of cost reduction strategies and incentives should be explored. The following are recommended:

- A. Cooperative Activities: One of the best means of lowering the cost of housing is for families to cooperate in the construction of new buildings. One method that can be employed is the formation of a group of 4-5 families to help each other build. The families collectively pay for the services of a mason or carpenter, trained in new construction methods, to supervise construction. The houses are built simultaneously so that they are all completed at approximately the same time (thereby lessening the possibility that one family would fail to assist the others once their house has been completed). Other forms of cooperative action can and should be developed and encouraged.
- B. Increased Financial Assistance: Improving houses to a basic minimum standard may make some families eligible for financial assistance from lending institutions. By working with both homebuilders and lenders, program implementers may be able to arrange loans that otherwise would not be available. Program implementers should be encouraged to develop financial assistance strategies and/or work with lending institutions in their areas to develop such programs. Possible activities include:
- Loan guarantees
 - Subsidized loans
 - Soft loans
 - Revolving loans
- C. Cost Reduction: In order to enable some families to participate, the cost of materials may have to be reduced. Program implementers should identify those materials that are critical and require cost reduction. The coordinating agency for the program should then help to identify methods

that can be used to reduce material costs. Methods for reducing costs include:

1. Payment of transportation costs;
2. Local production of components;
3. Subsidies.

In order to promote utilization of components such as hurricane fasteners or other relatively low-cost items, implementing agencies should be encouraged to distribute a limited number of these items free.

IMPLEMENTATION

The cooperation of many organizations in Haiti will be required in order to carry out the activities just described. The following is a list of agencies that could participate and some suggested roles each might play.

Non-Governmental Agencies:

- A. OXFAM: OXFAM has had previous experience in this type of program, but in Haiti OXFAM's experience in the housing sector has been limited to a conventional housing reconstruction project carried out following Hurricane Cleo in 1964. An excellent contribution would be to provide technical resources and experienced personnel from other countries where similar programs have taken place to help initiate the activities and to demonstrate what can be done. Other possibilities might include financial support for initial training activities and/or development of training aids.
- B. CRS: CRS is not currently involved in housing but a number of construction projects have been undertaken (mainly roads). In addition, CRS supported several housing reconstruction programs in the south following Hurricane Allen. Some promising leaders and builders might be identified from these programs that could form a nucleus of builders or building instructors.
- C. Groupe Technologie Intermediare d'Haiti (GTIH): GTIH coordinates with various AT centers and conducts training in small-scale rural technologies. The group could be designated a "lead agency" to coordinate overall activities, to conduct training, and to establish and maintain a compre-

hensive library on building and construction. Furthermore, as a resource to the voluntary agencies of Haiti, they are in a good position to encourage and help the NGO's develop their own housing and vulnerability reduction programs.

- D. Foster Parents Plan: FPP is currently carrying out an integrated rural development program in the region, one component of which is housing. FPP could expand the training component and provide a nucleus for training builders and instructors from other areas. FPP could also provide financial and technical support.
- E. AT Centers: AT centers have been established in several rural communities in the south. These centers are ideal facilities for training activities.

Governmental Agencies

- F. AID Mission: Appropriate roles for the AID Mission might include:
 - 1. Stimulating interest in the proposed activities;
 - 2. Supporting preparation of the training aids;
 - 3. Providing technical assistance to the implementing agencies;
 - 4. Providing financial support to program implementers;
 - 5. Providing financial and technical support to the coordinating agency.
- G. Government of Haiti: The GOH, acting either through a ministry, the newly-established disaster preparedness office or the Office Nationale de Technologie, could undertake the following roles:
 - 1. Serving as overall coordinator of the implementing activities;
 - 2. Establishing a national housing information center and reference library;
 - 3. Providing financial assistance to families participating in the program;

4. Providing subsidized materials to program participants.

Other possible assisting agencies are:

- H. CARE: CARE is currently initiating a similar housing project in the Dominican Republic. They might be willing to share expertise and training materials or to provide technical assistance when the D.R. program is underway.
- I. Cooperative Housing Foundation (CHF): CHF is currently advising the Office Nationale du Logement of the GOH on sites and services projects in Port-au-Prince. They may have resources that could be applied to self-help housing activities in other areas.

APPENDIX I:

RECOMMENDED TRAINING AIDS AND PROMOTIONAL MATERIALS

Four separate sets of materials will be required to create public awareness of housing conditions and to train people in safer construction methods. Materials already available, which only require translation into Creole, are marked with an asterisk (*). Those that can be quickly adapted from existing publications are marked with a double asterisk (**). Many of the materials can be used interchangeably between sets.

MATERIALS REQUIRED FOR TRAINING INSTRUCTORS

- ** 1. Instructor's Manual: A comprehensive manual including sections on construction techniques, building details, instructional techniques and guidelines for training including how to prepare a class, how to effectively demonstrate building details, and how to prepare course outlines for topics not discussed. Suggested course outlines and checklists for each class in a training program should be included.
- 2. Instructor's versions of all training aids.

MATERIALS FOR PUBLIC AWARENESS AND PROMOTIONAL ACTIVITIES

- * 3. Film: Building for Safety in Hazardous Areas: A 12-minute, 16mm film explaining how the forces of hurricanes and earthquakes damage houses. This film could be used for both public information activities and portions of the instructional program. The film is animated and shows how buildings collapse and how simple construction techniques can improve performance. The film is in English and Spanish, but a Creole sound track could easily be made.
- 4. Audio-cassettes for Radio Programs: A series of audio-cassettes for distribution to radio stations, describing methods for improving buildings, providing information about hurricanes and safety, and announcing specific activities that are about to commence.
- ** 5. Posters: Posters announce program activities and stimulate interest in the program. Posters should describe where interested parties can obtain more information.

- ** 6. "How Safe is Your House?": Pamphlet to help families determine whether their houses need improvement or modification. The pamphlet should use a checklist and numerical grading system to help homeowners determine the relative safety of a building, and it should help them determine the relative value of various options they may choose. (A simplified version of the checklist could be produced and printed in newspapers to help encourage people to determine safety at the beginning of each hurricane season.)

MATERIALS FOR TRAINING BUILDERS

Materials are needed to explain the construction techniques for new buildings and modification/retrofitting of existing buildings.

A. New Buildings:

- * 7. Introduction to Wind Resistant Construction: A Guide for Agencies in the Caribbean: Booklet produced by INTERTECT for OXFAM and Catholic Relief Services, to be used to introduce the basic concepts of wind resistant construction to persons who can read.
8. "How to Build a Safe Stone House": Pamphlet that should be prepared using drawings instead of text to convey the information about safe housing construction. It would also describe methods for reducing costs and for building without wood columns.
9. "How to Build a Safe Ajoupa or Klisé House": Pamphlet to serve as a guide for those building with ajoupa or klisé.
- ** 10. "How to Build a Safe Wood Frame House": Pamphlet to serve as a guide for those building new wood frame houses.
- * 11. "How to Build a Safe House of Block": Pamphlet to serve as a guide for those building with block.
- ** 12. "Techniques of Concrete Construction": Pamphlet to demonstrate correct techniques for preparing and using cement and concrete (can be prepared from existing materials available from VITA and Peace Corps).
13. Flipcharts: Training aids to amplify points made in the various booklets, for use by instructors in the classes. These charts should be prepared on cloth or plastic to make them more durable.

14. Scale Models of Each Housing Type: Models that should be prepared depicting the correct construction for each type of house. These would show the proper placement of braces and fasteners, and would demonstrate correct techniques for joining and splicing wood and other materials.

B. Existing Buildings:

15. "Emergency Methods to Protect Your House": Pamphlet to guide owners in ways to correctly strengthen their buildings before a hurricane strikes. Some of the methods are shown in Appendix II of this report. The pamphlet should discuss the relative value of the different types of modifications and retrofitting measures possible and provide guidance in how to determine the structural integrity of various components.
16. "How to Strengthen Existing Buildings": Booklet designed for contractors to illustrate techniques for improving hurricane and earthquake resistance and how to help owners determine if these measures would be economically justified.

INSTRUCTIONAL MATERIALS FOR IMPROVING BUILDING SKILLS

Many materials already exist that could be used to teach builders and homeowners correct construction methods and techniques. These should be acquired and translated into Creole. VITA, ITDG and the U.S. Department of Housing & Urban Development have publications in French that could be translated.

The shortage of tools could be addressed by teaching builders how to make and maintain primary tools. Some teaching aids exist, but most would have to be prepared and translated into Creole. VITA, ITDG and/or INTERTECT could provide assistance in developing these materials.

APPENDIX II:

EMERGENCY MEASURES TO PROTECT SMALL BUILDINGS FROM HURRICANES

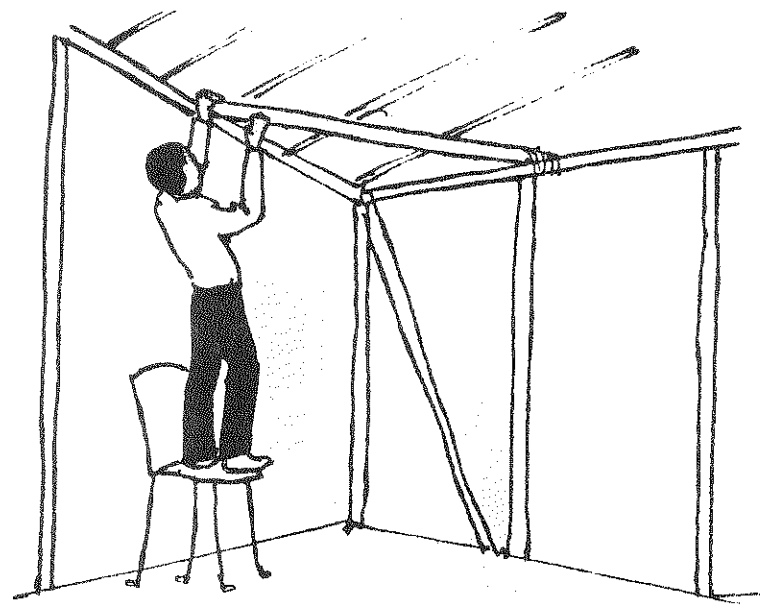
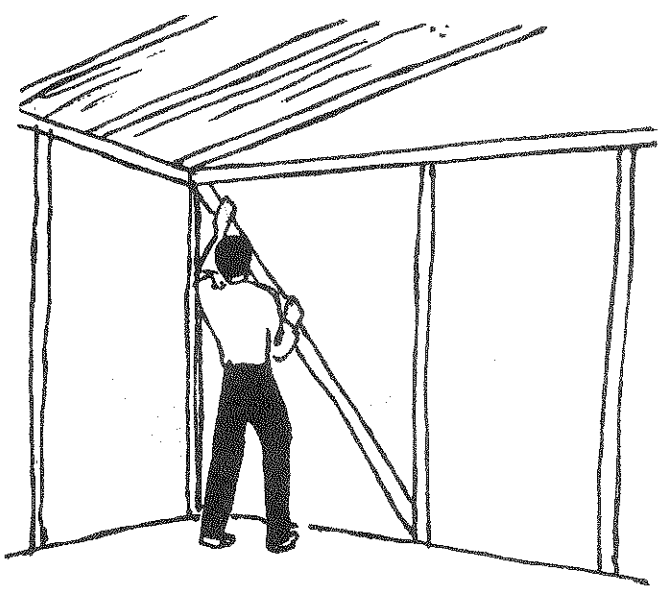
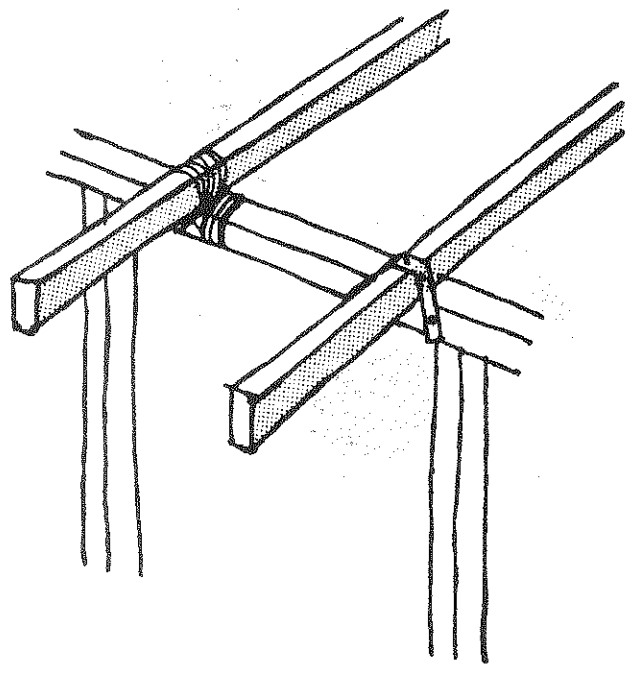
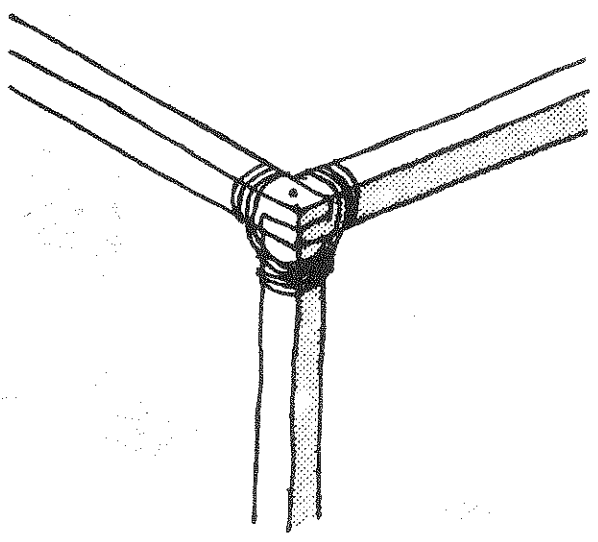

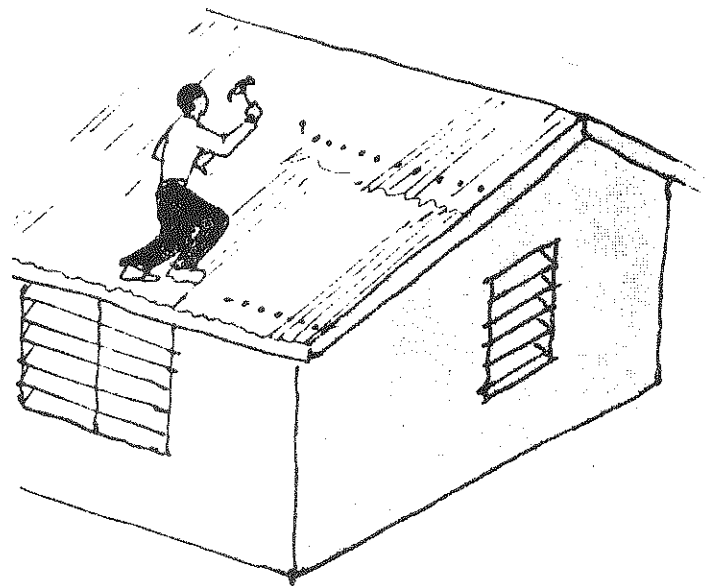
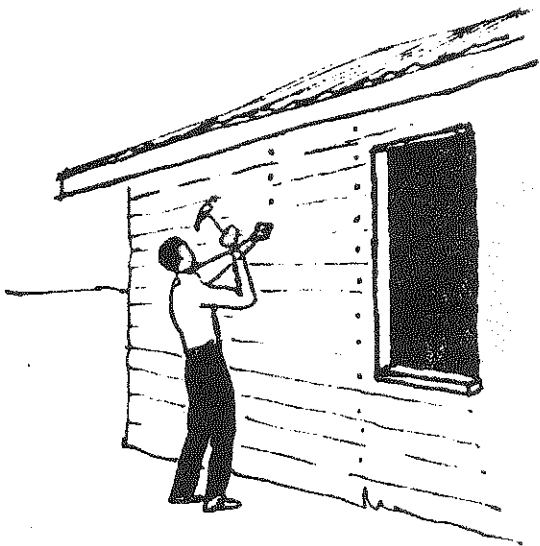
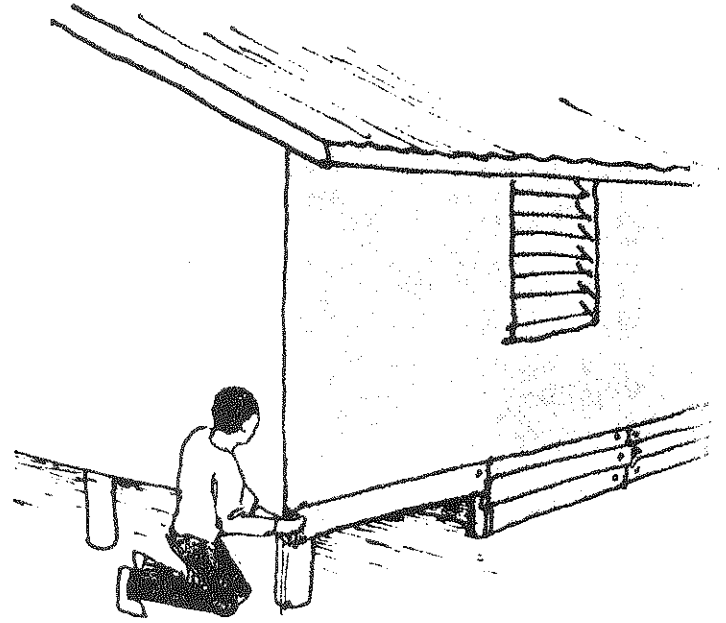
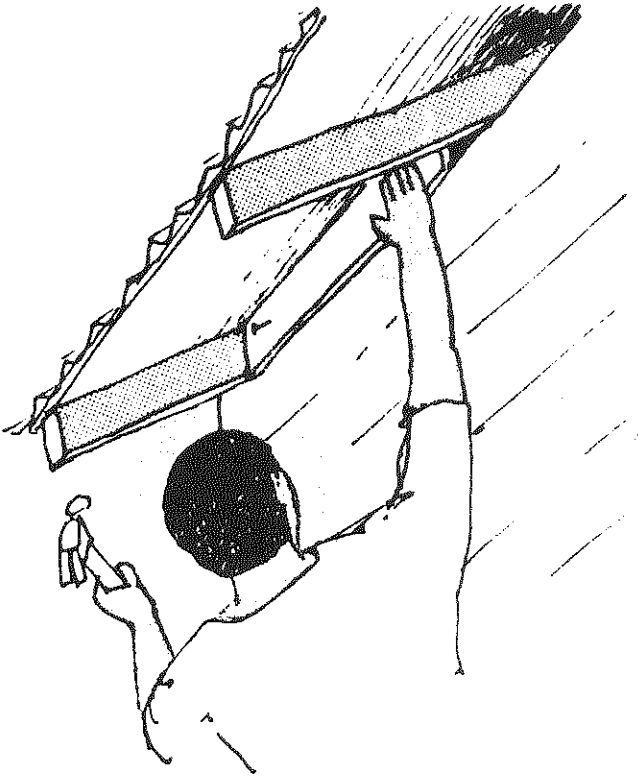

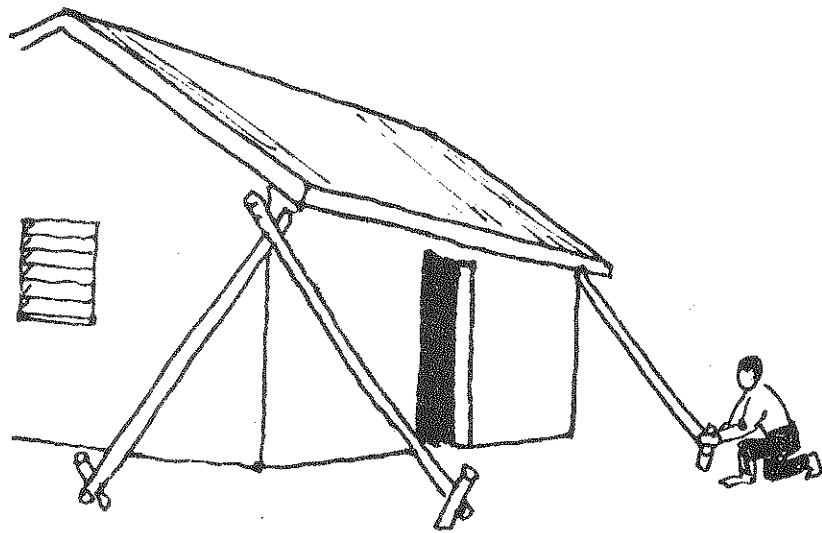
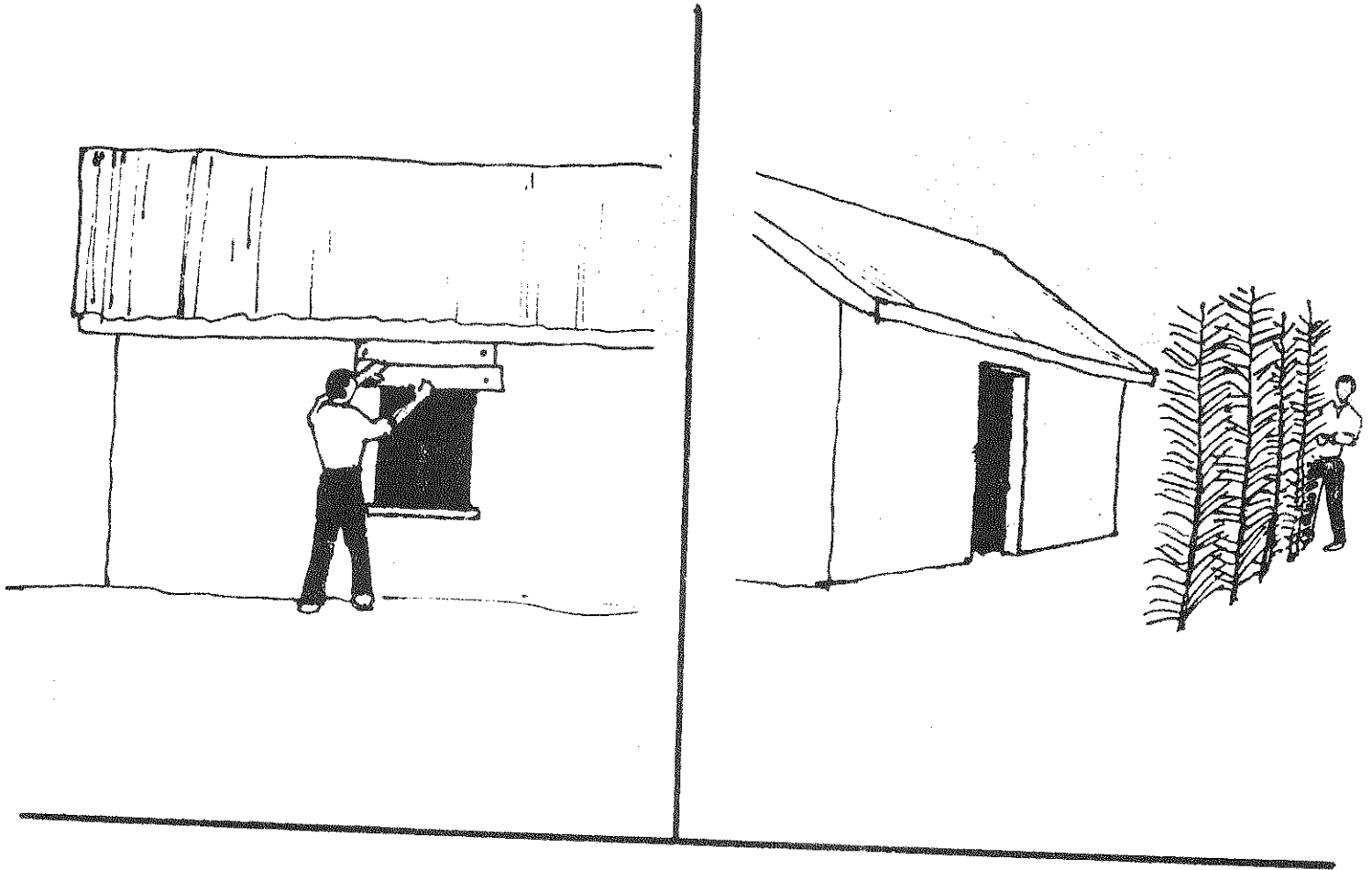

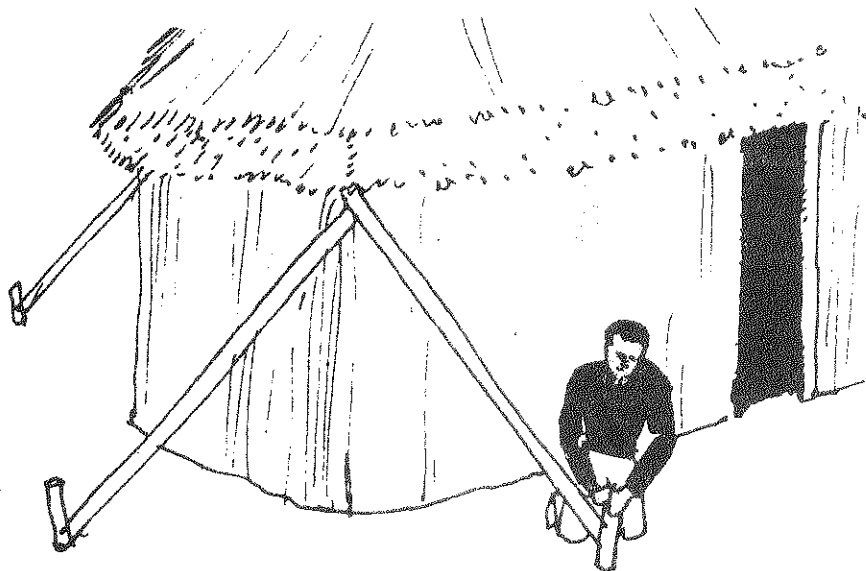
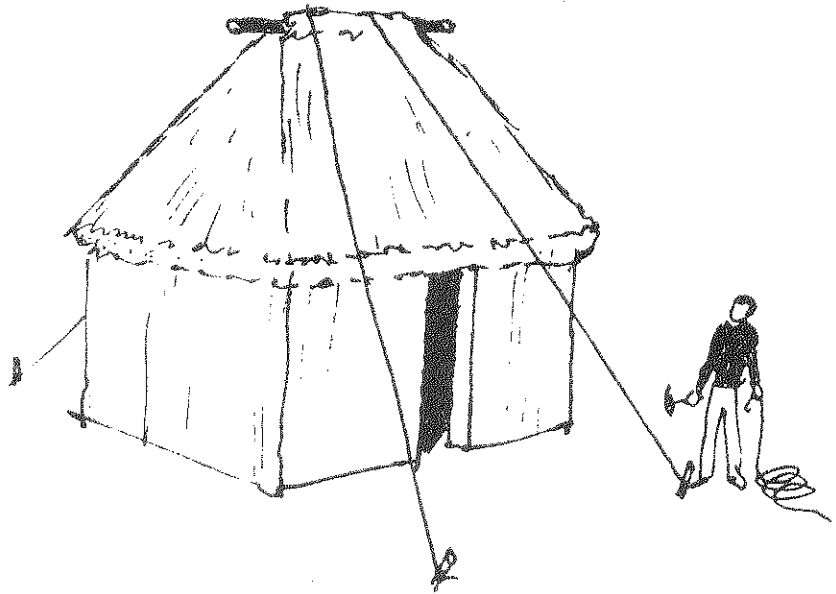
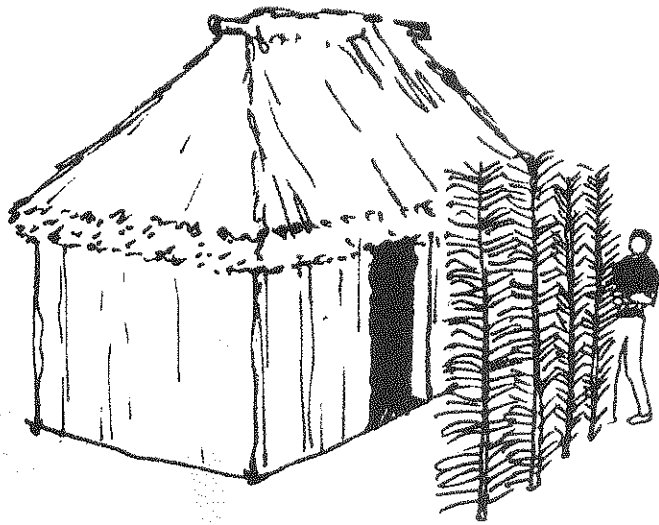

YAGTAROBAL STOUUON TEBRO?
SPUTUUCIADA TO .YRSC .E.O
20722 IF ,ROBYCAN

APPENDIX III: WOODS INTRODUCED IN HAITI

WOOD INTRODUCED IN REFORESTATION PROGRAMS

The following woods are being introduced in Haiti under reforestation programs:

- Leucaena
- Neem
- Cassia Siamia
- Casuarina
- Cassia Marginata
- Eucalyptus
- Oak

Casuarina, Cassia Siamia and Cassia Marginata are used for the production of charcoal. Leucaena and Neem are used for charcoal production and also for soil stabilization. These woods are unsuitable for construction purposes. Eucalyptus and Oak are the only woods currently being planted in Haiti that should be used in housing construction.

Detailed information about the different varieties can be obtained from the Forest Products Laboratory (U.S. Department of Agriculture, Madison, Wisconsin 53705, USA). Sample reports on Neem and Casuarina are attached to this Appendix.

AZADIRACHTA SPP.

FROM:
FOREST PRODUCTS LABORATORY
U.S. DEPT. OF AGRICULTURE
MADISON, WI 53705

NEEM
MARANGGO

Family: Meliaceae

Other Common Names: Ranggail (Sabah), Sentang (Malaya),
Ranggu (Sarawak), Tamaka (Burma).

Distribution: Throughout the Indo-Malayan regions, well
distributed in lowland forests. Extensively planted as an
ornamental and for shade in gardens and along roadsides in
the tropics.

THE TREE With a clear cylindrical trunk about 20 to 45 ft in length;
diameters of 3 to 5 ft; bole is sometimes fluted.

THE WOOD General Characteristics: Heartwood reddish-brown, darkening
on exposure; sapwood straw-colored to pale red, not sharply
demarcated. Texture moderately coarse; grain interlocked;
dull to somewhat lustrous; has a faint cedary odor when
fresh which fades on drying, no distinctive taste.

Weight: Basic specific gravity (ovendry weight/green volume)
0.52; air-dry density 40 pcf.

Mechanical Properties: (First set of data based on the 2-cm
standard, the second set on the 2-in. standard.)

Moisture content	Bending strength	Modulus of elasticity	Maximum crushing strength
	<u>Psi</u>	<u>1,000 psi</u>	<u>Psi</u>
Green (3)*	11,000	1,120	5,300
12%	14,300	1,270	7,370
12% (2)	11,480	1,009	6,680

Janka side hardness 1,220 lb for green material
and 1,460 lb at 12% moisture content.

*See "Additional Reading" for references.

Drying and Shrinkage: The timber is reported to season well with little or no degrade. Kiln schedule T2-D4 is suggested for 4/4 stock and T2-D3 for 8/4. Shrinkage green to air dry: radial 2.2%; tangential 4.3%; volumetric 6.5%. Movement in service is rated as small.

Working Properties: Works well with hand and machine tools; a fine smooth finish is produced.

Durability: A. excelsa reported not resistant to decay while A. indica is rated as durable to moderately durable.

Preservation: Heartwood is not treatable but sapwood absorption is good using a pressure-vacuum system.

Uses: Veneer and plywood, furniture and cabinetwork, joinery, carving.

ADDITIONAL READING

1. Burgess, P. F.
1966. Timbers of Sabah. Sabah For. Rec. No. 6.
2. Pearson, R. S., and H. P. Brown.
1932. Commercial timbers of India. Gov. of India
Central Publ. Br., Calcutta.
3. U.K. Forest Products Research Laboratory.
1968. Reports on overseas timbers. No. 11. Report on
two consignments of Neem (Azadirachta indica) from the
Republic of the Sudan. FPRL consignments Nos. 1307 and
1374, Forest Products Research Laboratory, Princes
Risborough.

CASUARINA SPP.

CASUARINA

Family: Casuarinaceae

Other Common Names: She-Oak (Australia), Aru (Sabah), Ru (Malaya), Surra, Serva (India), Agoho (Philippines), Velau (Fiji Islands), Tjemara (Indonesia), Bois de fer de rivièrè (New Caledonia).

Distribution: Malay Peninsula, Burma, Australia, Philippines, and islands of the Pacific. Widely cultivated throughout the tropics. C. equisetifolia particularly favored along seashores.

THE TREE

A rapidly growing tree that may reach a height of 120 to 150 ft with trunk diameters up to 24 in. Bole is often fluted, straight, and cylindrical.

THE WOOD

General Characteristics: Heartwood light red to reddish-brown, becoming darker in older trees; sapwood buff-colored, usually distinct from heartwood. Texture fine, grain straight to interlocked; luster is low; without distinctive odor or taste. Species with wide rays have an attractive figure when quartered.

Weight: Basic specific gravity (ovendry weight/green volume) 0.83; air-dry density 64 pcf.

Mechanical Properties: (First set of data based on the 2-in. standard; the second set on the 2-cm standard.)

Moisture content	Bending strength	Modulus of elasticity	Maximum crushing strength
	<u>Psi</u>	<u>1,000 psi</u>	<u>Psi</u>
Green (2)*	14,300	1,890	6,600
12%	25,000	3,310	11,000
12% (1)	21,400	1,830	12,100

Janka side hardness 1,980 lb for green material and 3,200 lb for dry. Amsler toughness 182 in.-lb at 12% moisture content (2-cm specimen).

*See "Additional Reading" for references.

Drying and Shrinkage: The wood dries at a moderate rate but usually with considerable warp and checking. Kiln schedule T2-C2 may be suitable for 4/4 stock. Shrinkage green to oven-dry: radial 6.4%; tangential 11.7%; volumetric 17.6%.

Working Properties: Saws with difficulty and also difficult to work with hand and machine tools because of the high density, finishes smoothly.

Durability: Heartwood is generally reported as nondurable. In Puerto Rico the wood is rated as susceptible to dry-wood termites; but in the Philippines, it is rated as resistant.

Preservation: Sapwood is readily treated; heartwood absorption is irregular and only 5 pcf when treated by a full-cell schedule.

Uses: Construction under cover, tool handles, posts and poles (treated), charcoal, tests in India indicate the wood is suitable for chemical and semichemical pulps.

ADDITIONAL READING

1. Burgess, P. F.
1966. Timbers of Sabah. Sabah For. Rec. No. 6.
2. Lauricio, F. M., and S. B. Bellosillo.
1966. The mechanical and related properties of Philippine woods. The Lumberman 12(5):66+A-H.
3. Pearson, R. S., and H. P. Brown.
1932. Commercial timbers of India. Gov. of India. Central Publ. Br., Calcutta.
4. Sallenave, P.
1955. Propriétés physiques et mécaniques des bois tropicaux de l'union Française. Publ. Centre Tech. For. Trop. No. 8.